



Scientific Graphing and Analysis Software

Origin is on all Physics 403 computers.

What it can do:

1. Graphical presentation of data

2. Data analysis

3. Preparation of publication-quality figures

- Specially designed for scientific graphics
- “Standard” Windows application, does not require knowledge of C++ or any other high level computer language
- Can write special functions or procedures using Origin programming tools

Importing data

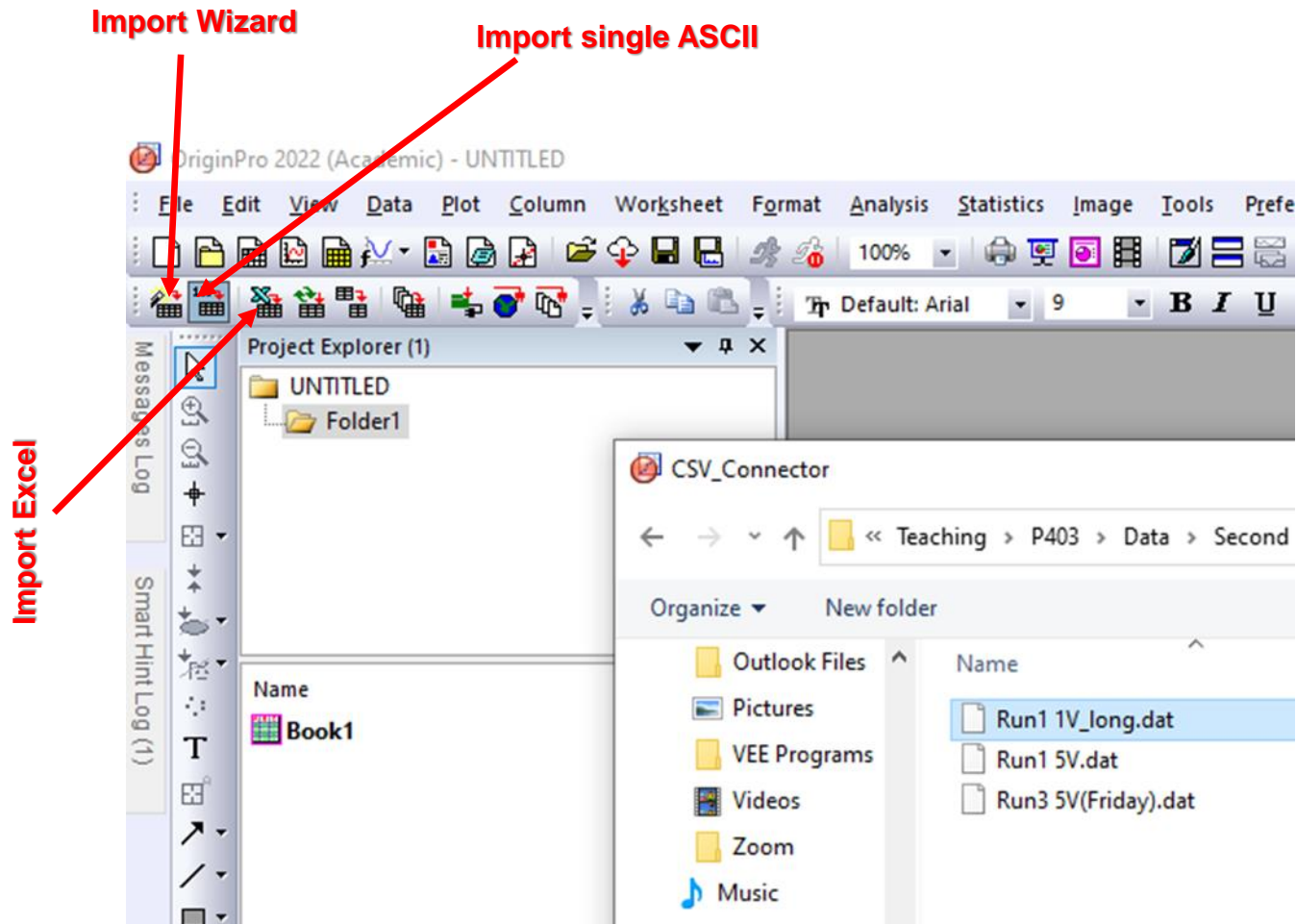

Can drag and drop .dat or .txt files into empty spreadsheet
Or import files

Graphical presentation of data: Basic Plot

Plot menu

The screenshot displays the OriginPro 2023 software interface. The title bar indicates the file path: "SS..opju - E:\Teaching\P403\Spring 2023\Lectures\Origin\ - /Folder1/ - OriginPro 2023 (Academic)". The menu bar includes File, Edit, View, Data, Plot, Column, Worksheet, Format, Analysis, Statistics, Image, Tools, Preferences, Connectivity, Window, and Help. A red arrow points to the "Plot" menu. The toolbar contains various icons for file operations, editing, and analysis. The main workspace shows a data table window titled "Run11Vlong - Run1 1V_long.dat". The table has columns for A(X), B(Y), C(Y), D(Y), and E(Y). The first row of data is highlighted in yellow. Below the table, there are sparklines for each column, showing trends: A(X) increases, B(Y) fluctuates around a negative value, C(Y) fluctuates around a positive value, D(Y) fluctuates around a positive value, and E(Y) fluctuates around a positive value.

	A(X)	B(Y)	C(Y)	D(Y)	E(Y)
Long Name	time (s)	Vdt	T(K)	P (mm)	Tp (K)
Units					
Comments					
F(x)=					
Sparklines					
1	0.07	-1.6984	1.58361	2.36926	1.42113
2	0.27	-1.6995	1.51669	2.5413	1.43442
3	0.41	-1.6989	1.55345	2.36926	1.42113
4	0.55	-1.6989	1.55345	2.44746	1.42726
5	0.69	-1.6984	1.58361	2.44746	1.42726
6	0.82	-1.6989	1.55345	2.44746	1.42726
7	0.96	-1.6989	1.55345	2.44746	1.42726
8	1.1	-1.6989	1.55345	2.44746	1.42726
9	1.24	-1.6989	1.55345	2.5413	1.43442

Graphical presentation of data: Basic Plot

Plot menu

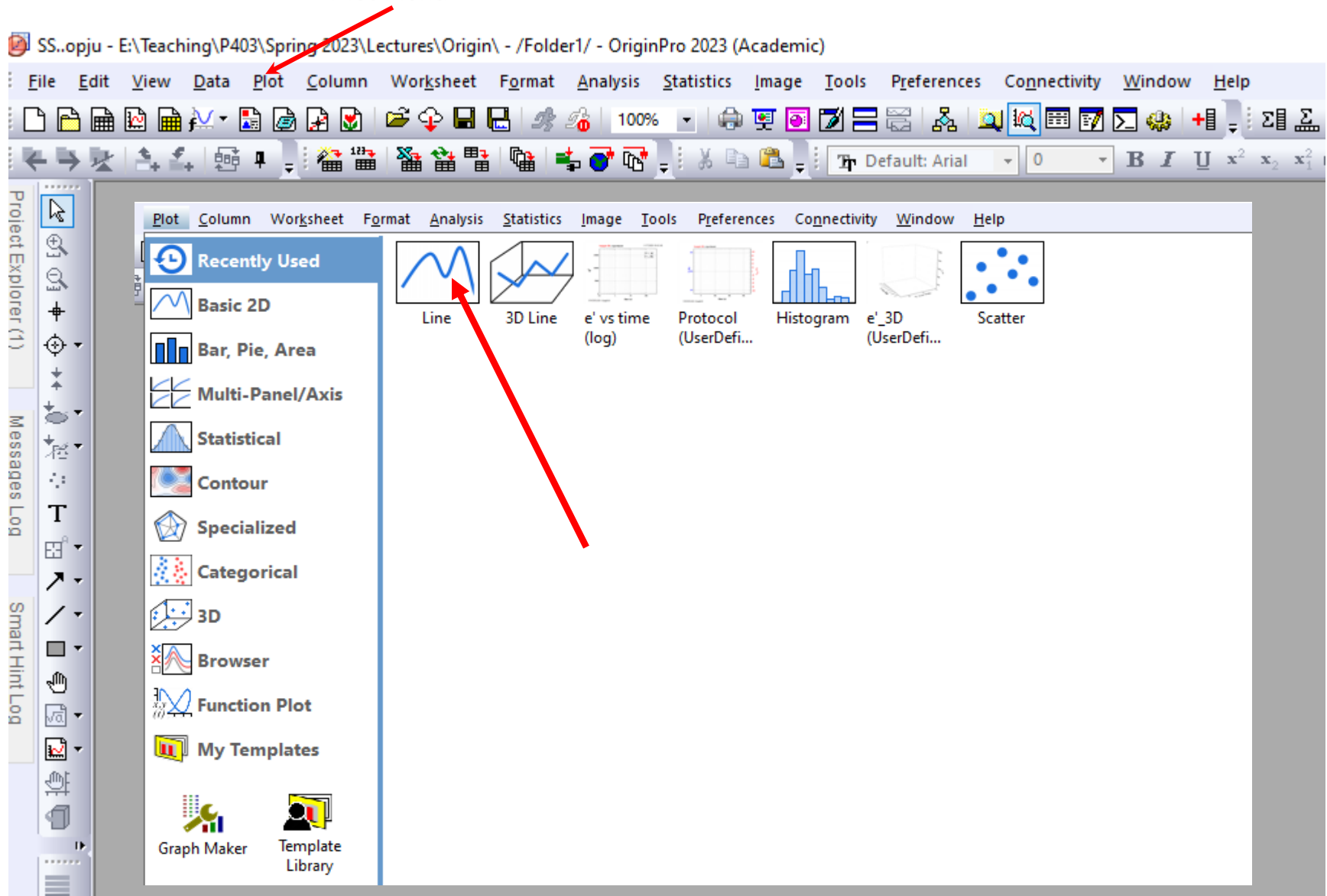

Graphical presentation of data: Basic Plot

Plot menu

SS..opju - E:\Teaching\P403\Spring 2023\Lectures\Origin\ - /Folder1/ - OriginPro 2023 (Academic)

File Edit View Data Plot Column Worksheet Format Analysis Statistics Image Tools Preferences Connectivity Window Help

Plot Setup: Select Data to Create New Plot

Plot Type:

- Line
- Scatter
- Line + Symbol
- Column / Bar
- Area
- Stacked Area
- Fill Area
- High - Low - Close
- Floating Column
- XYAM Vector
- XYXY Vector
- Bubble
- Color Mapped

Show(S) [Run11Vlong]"Run1 1V_long"

X	Y	yEr	L	Column	Long Name	Comments	Sampling Interval	Position
<input type="checkbox"/>	<input type="checkbox"/>	<input type="checkbox"/>	<input type="checkbox"/>	<autoX>	From/Step=			0
<input type="checkbox"/>	<input type="checkbox"/>	<input type="checkbox"/>	<input type="checkbox"/>	A	time (s)			1
<input type="checkbox"/>	<input type="checkbox"/>	<input type="checkbox"/>	<input type="checkbox"/>	B	Vdt			2
<input type="checkbox"/>	<input type="checkbox"/>	<input type="checkbox"/>	<input type="checkbox"/>	C	T(K)			3
<input type="checkbox"/>	<input type="checkbox"/>	<input type="checkbox"/>	<input type="checkbox"/>	D	P (mm)			4
<input type="checkbox"/>	<input type="checkbox"/>	<input type="checkbox"/>	<input type="checkbox"/>	E	Tp (K)			5
<input type="checkbox"/>	<input type="checkbox"/>	<input type="checkbox"/>	<input type="checkbox"/>	F	Uac (V)			6
<input checked="" type="checkbox"/>	<input type="checkbox"/>	<input type="checkbox"/>	<input type="checkbox"/>	G	f (Hz)			7
<input type="checkbox"/>	<input type="checkbox"/>	<input type="checkbox"/>	<input type="checkbox"/>	H	X (V)			8
<input type="checkbox"/>	<input type="checkbox"/>	<input type="checkbox"/>	<input type="checkbox"/>	I	Y(V)			9
<input type="checkbox"/>	<input checked="" type="checkbox"/>	<input type="checkbox"/>	<input type="checkbox"/>	J	R(V)			10

OK

Cancel

Graph Maker

Template Library

Graphical presentation of data: Basic Plot

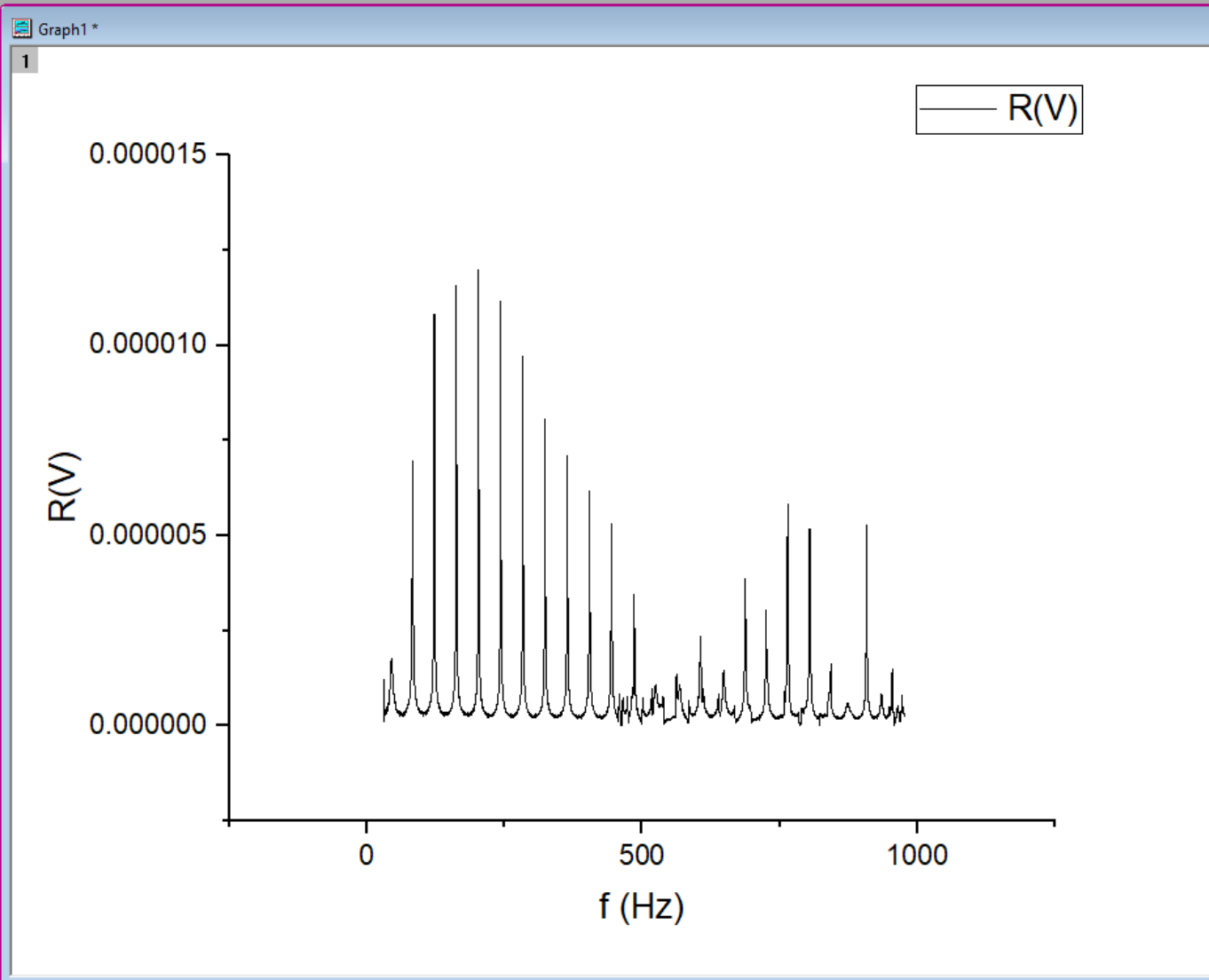

Graphical presentation of data: Basic Plot

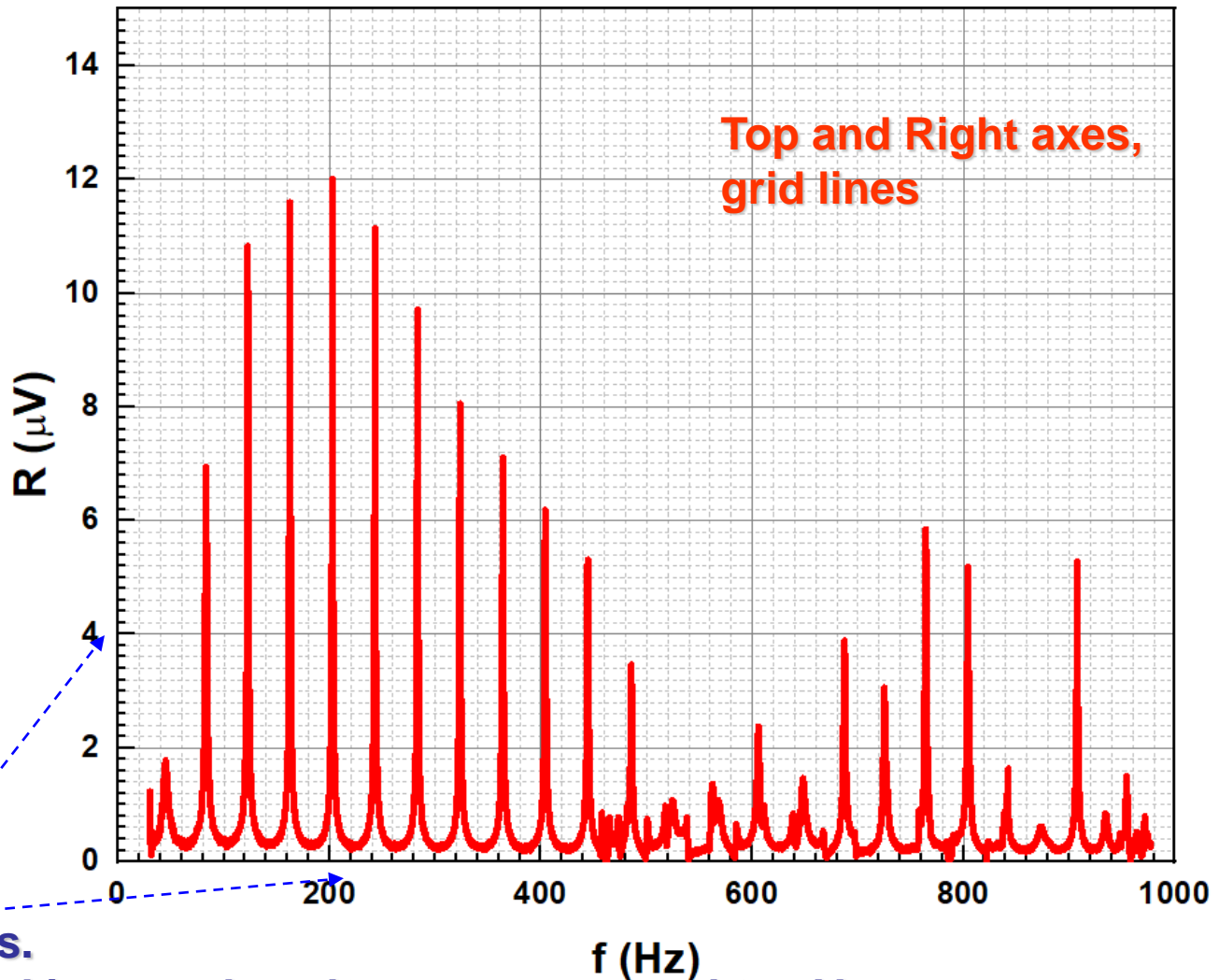

Bold tick labels.

For a better-looking graph, volts were converted to μV

Graphical presentation of data: Templates

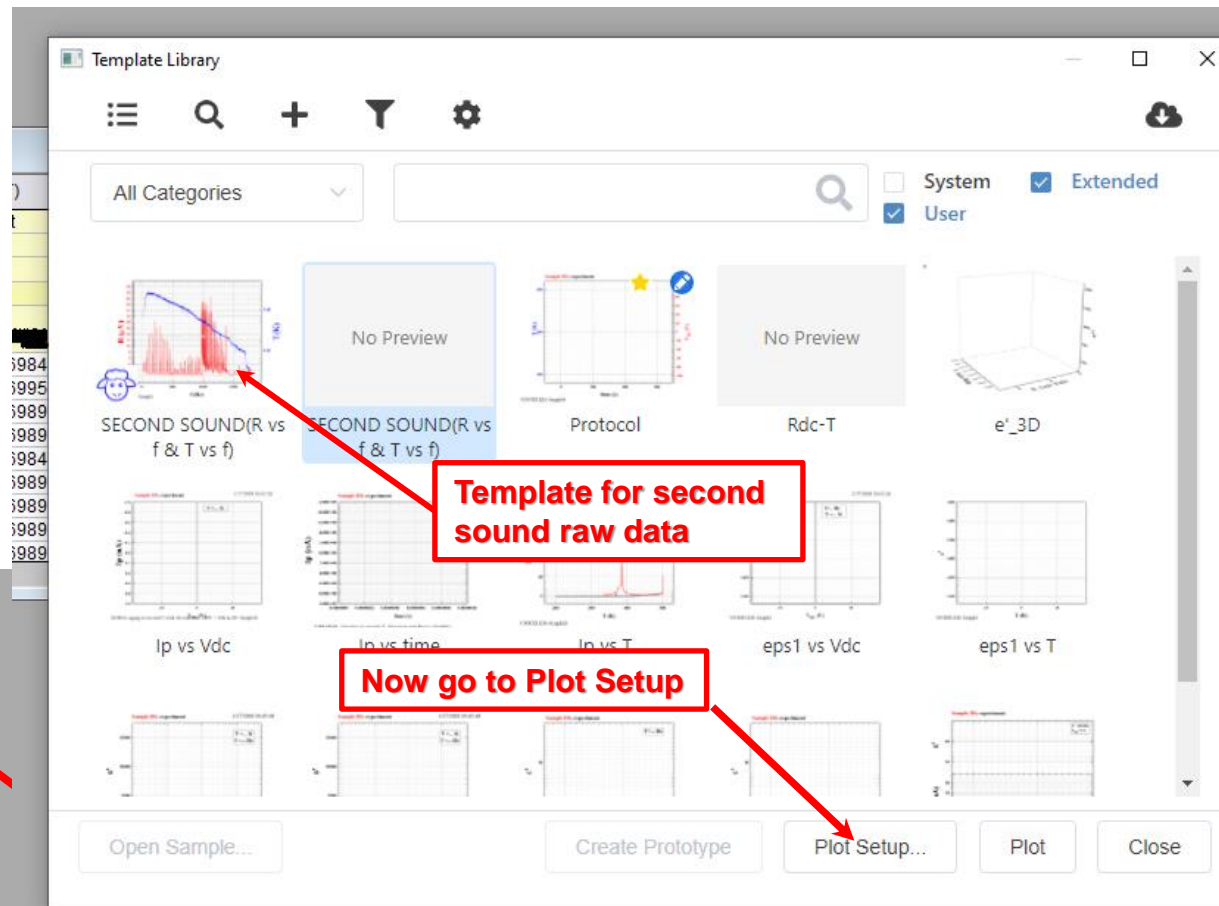

Templates Library

Template for second sound raw data

Now go to Plot Setup



<< Start Menu (F1)

Graphical presentation of data: Templates

Plot Setup: Select Data to Create New Plot

Plot Type:

	X	Y	yEr	L	Column	Long Name	Comments	Sampling Interval	Position
Line	<input type="checkbox"/>	<input type="checkbox"/>	<input type="checkbox"/>	<input type="checkbox"/>	< autoX>	From/Step=			0
Scatter	<input type="checkbox"/>	<input type="checkbox"/>	<input type="checkbox"/>	<input type="checkbox"/>	A	time (s)			1
Line + Symbol	<input type="checkbox"/>	<input type="checkbox"/>	<input type="checkbox"/>	<input type="checkbox"/>	B	Vdt			2
Column / Bar	<input type="checkbox"/>	<input type="checkbox"/>	<input type="checkbox"/>	<input type="checkbox"/>	C	T(K)			3
Area	<input type="checkbox"/>	<input type="checkbox"/>	<input type="checkbox"/>	<input type="checkbox"/>	D	P (mm)			4
Stacked Area	<input type="checkbox"/>	<input type="checkbox"/>	<input type="checkbox"/>	<input type="checkbox"/>	E	Tp (K)			5
Fill Area	<input type="checkbox"/>	<input type="checkbox"/>	<input type="checkbox"/>	<input type="checkbox"/>	F	Uac (V)			6
High - Low - Close	<input type="checkbox"/>	<input type="checkbox"/>	<input type="checkbox"/>	<input type="checkbox"/>	F	Uac (V)			6
Floating Column	<input checked="" type="checkbox"/>	<input type="checkbox"/>	<input type="checkbox"/>	<input type="checkbox"/>	G	f (Hz)			7
XYAM Vector	<input type="checkbox"/>	<input type="checkbox"/>	<input type="checkbox"/>	<input type="checkbox"/>	H	X (V)			8
XYXY Vector	<input type="checkbox"/>	<input type="checkbox"/>	<input type="checkbox"/>	<input type="checkbox"/>	I	Y(V)			9
Bubble	<input type="checkbox"/>	<input checked="" type="checkbox"/>	<input type="checkbox"/>	<input type="checkbox"/>	J	R(V)			10
Color Mapped	<input type="checkbox"/>	<input type="checkbox"/>	<input type="checkbox"/>	<input type="checkbox"/>					

Plot List: Drag entries in 1st column to reorder or to move between layers. Right click for other options.

Plot	Range	Show	Plot Type	Legend
Layer 1	<input checked="" type="checkbox"/> Re	<input checked="" type="checkbox"/>		
Style Holder			Line	
Style Holder			Line	
Style Holder			Line	
Group				
Style Holder			Line	
Style Holder			Line	
Style Holder			Line	
Layer 2	<input checked="" type="checkbox"/> Re	<input checked="" type="checkbox"/>		

Graphical presentation of data: Templates

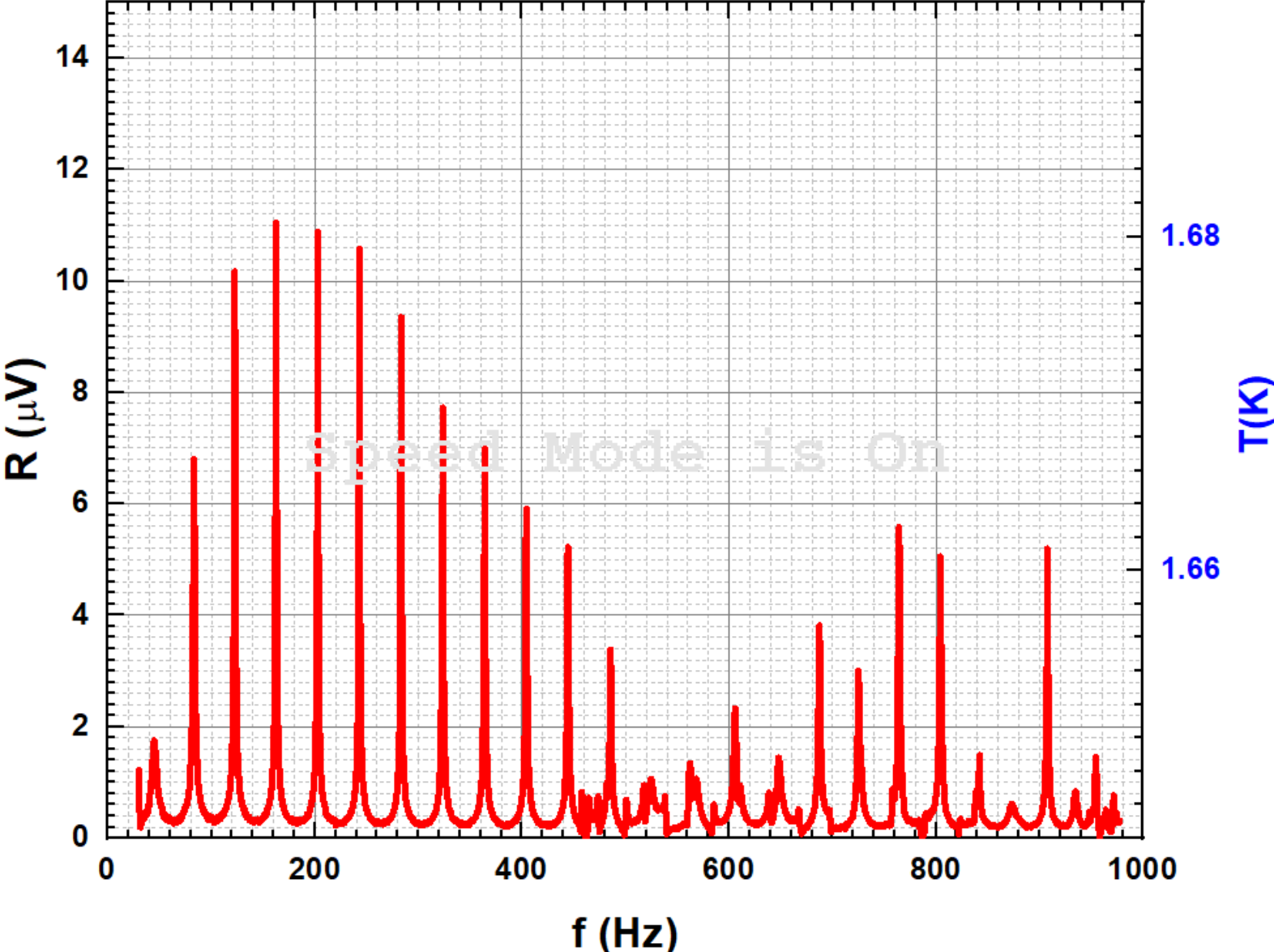

Graphical presentation of data: Extra Layer

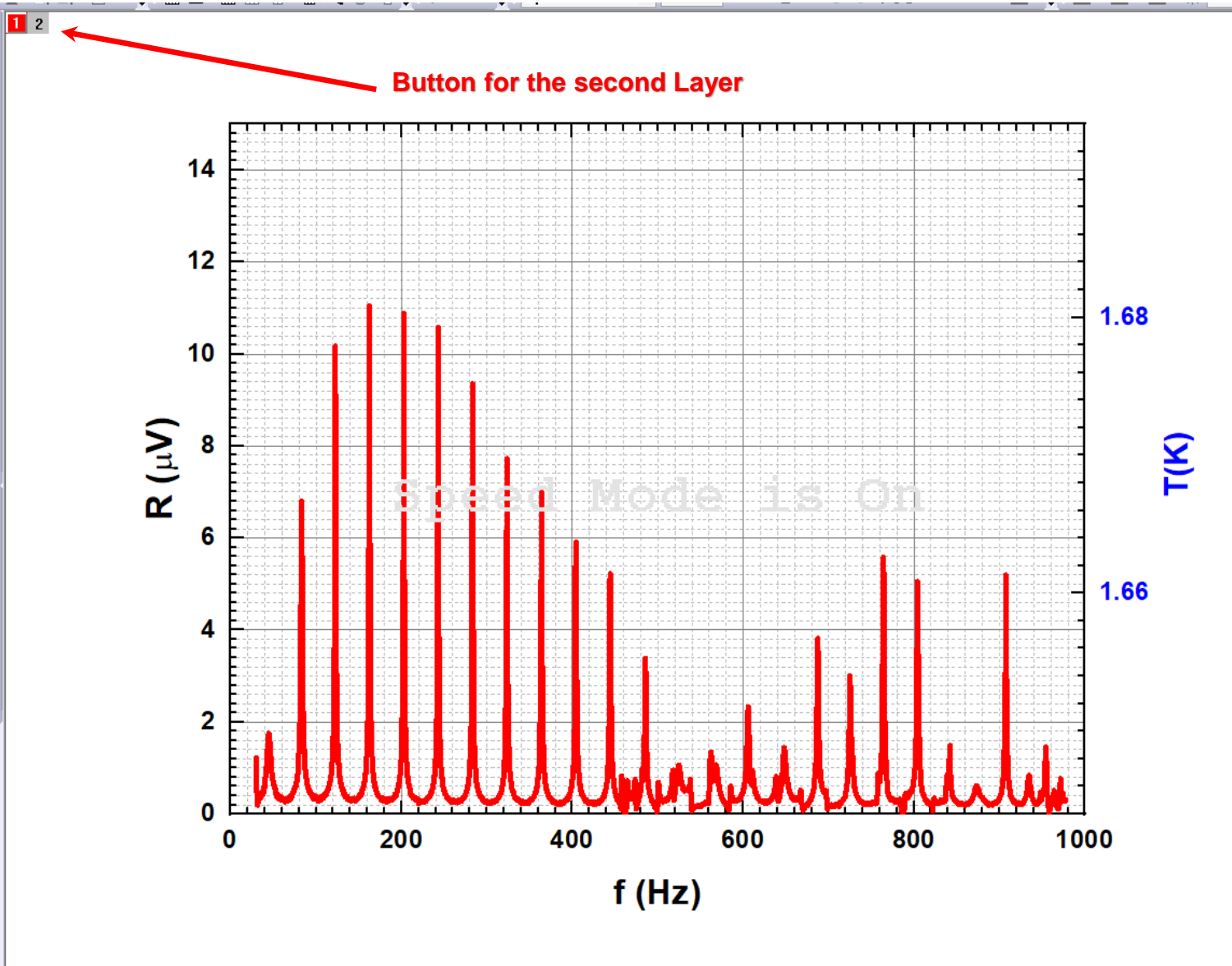

Button for the second Layer

Plot Setup: Configure Data Plots in Layer

Plot Type: Show(S) [Run11Vlong]"Run1 1V_long"

	X	Y	yEr	L	Column	Long Name	Comments	Sampling Interval	Position
Line	<input checked="" type="checkbox"/>	<input checked="" type="checkbox"/>	<input checked="" type="checkbox"/>	<input checked="" type="checkbox"/>	<autoX>	From/Step=			0
Scatter	<input type="checkbox"/>	<input type="checkbox"/>	<input type="checkbox"/>	<input type="checkbox"/>	A	time (s)			1
Line + Symbol	<input type="checkbox"/>	<input type="checkbox"/>	<input type="checkbox"/>	<input type="checkbox"/>	B	Vdt			2
Column / Bar	<input type="checkbox"/>	<input type="checkbox"/>	<input type="checkbox"/>	<input type="checkbox"/>	C	T(K)			3
Area	<input type="checkbox"/>	<input checked="" type="checkbox"/>	<input type="checkbox"/>	<input type="checkbox"/>	D	P (mm)			4
Stacked Area	<input type="checkbox"/>	<input type="checkbox"/>	<input type="checkbox"/>	<input type="checkbox"/>	E	Tp (K)			5
Fill Area	<input type="checkbox"/>	<input type="checkbox"/>	<input type="checkbox"/>	<input type="checkbox"/>	F	Uac (V)			6
High - Low - Close	<input type="checkbox"/>	<input type="checkbox"/>	<input type="checkbox"/>	<input type="checkbox"/>	G	f (Hz)			7
Floating Column	<input checked="" type="checkbox"/>	<input type="checkbox"/>	<input type="checkbox"/>	<input type="checkbox"/>	H	X (V)			8
XYAM Vector	<input type="checkbox"/>	<input type="checkbox"/>	<input type="checkbox"/>	<input type="checkbox"/>	I	Y(V)			9
XYXY Vector	<input type="checkbox"/>	<input type="checkbox"/>	<input type="checkbox"/>	<input type="checkbox"/>	J	R(V)			10
Bubble	<input type="checkbox"/>	<input type="checkbox"/>	<input type="checkbox"/>	<input type="checkbox"/>					
Color Mapped									
Bubble + Color Mapped									

Plot List: Drag entries in 1st column to reorder or to move between layers. Right click for other options.

Plot	Range	Show	Plot Type	Legend
Layer 1	<input type="checkbox"/> Rescale	<input checked="" type="checkbox"/>		
[Run1 1V_long.dat]Run1 1V_long! "f (Hz)"(X), "R(V)"(Y)	[1*:94707*] 30.01 < X < 977.07, 0 < Y < 1.20039E-5	<input checked="" type="checkbox"/>	Line	R(V)
Layer 2	<input checked="" type="checkbox"/> Rescale	<input checked="" type="checkbox"/>		
[Run1 1V_long.dat]Run1 1V_long! "f (Hz)"(X), "T(K)"(Y)	[1*:94707*] 30.01 < X < 977.07, 0 < Y < 1.58361	<input checked="" type="checkbox"/>	Line	T(K)

Preview OK Cancel Apply

Graphical presentation of data: Extra Layer

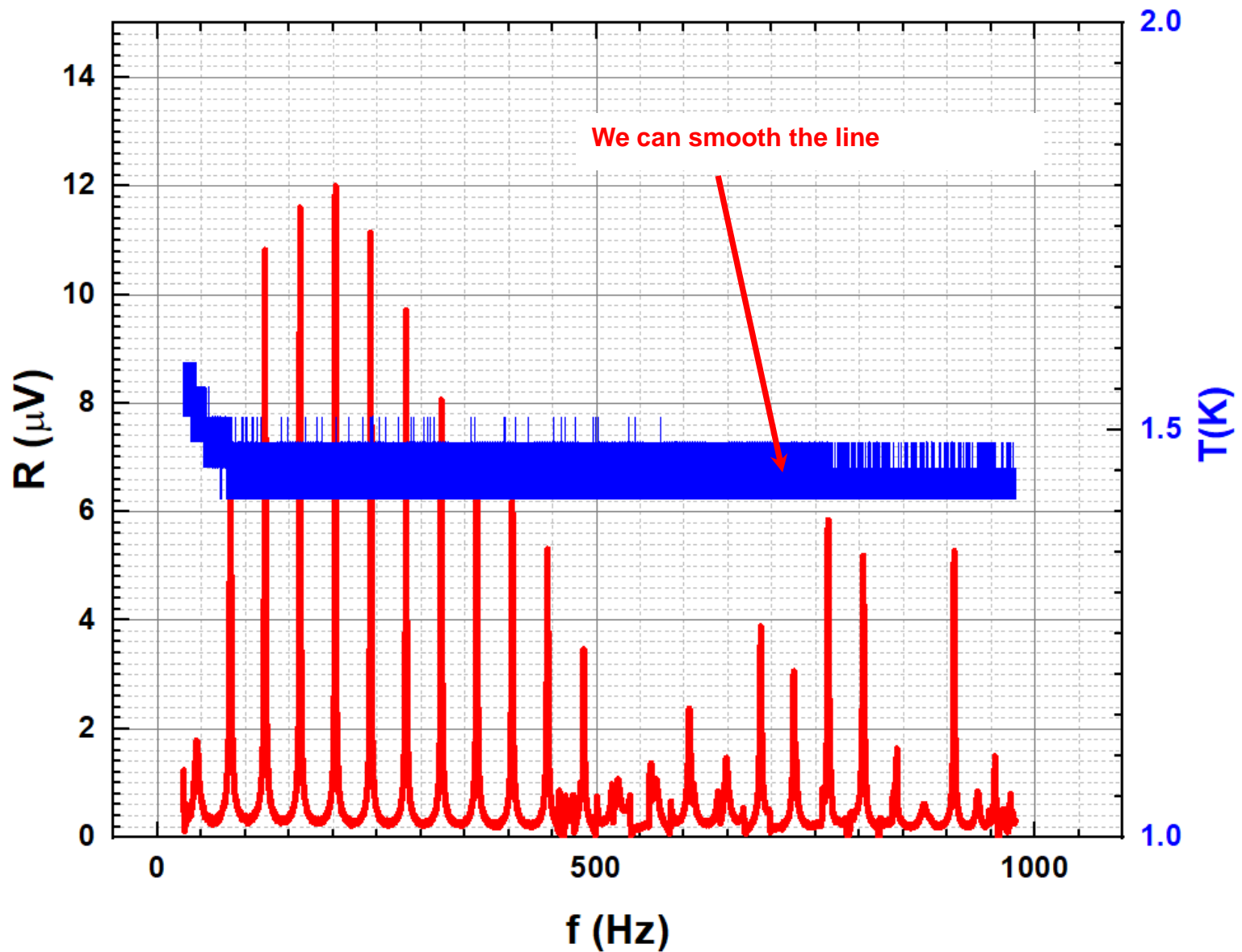

Graphical presentation of data: Extra Layer

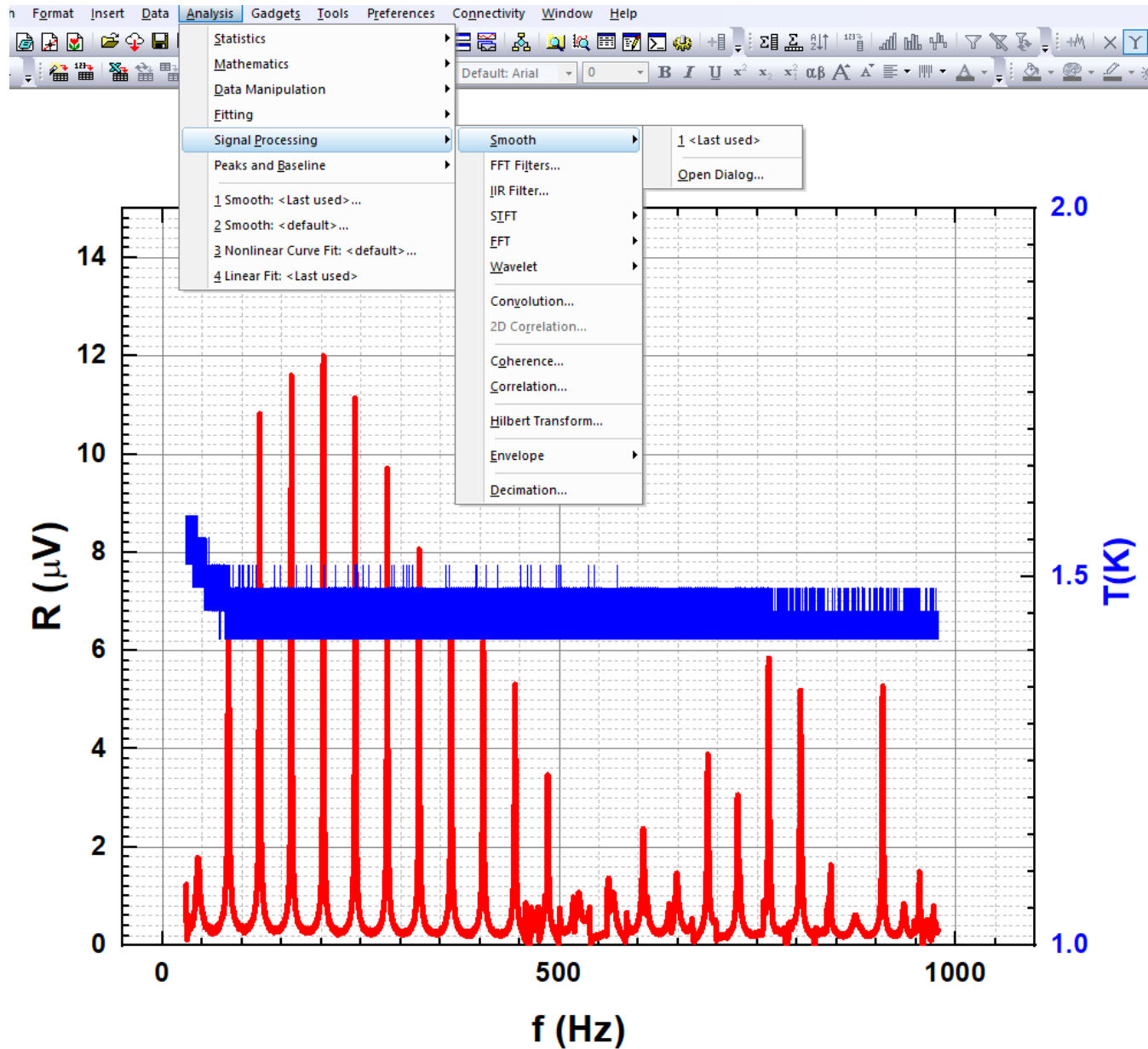

Graphical presentation of data: Extra Layer

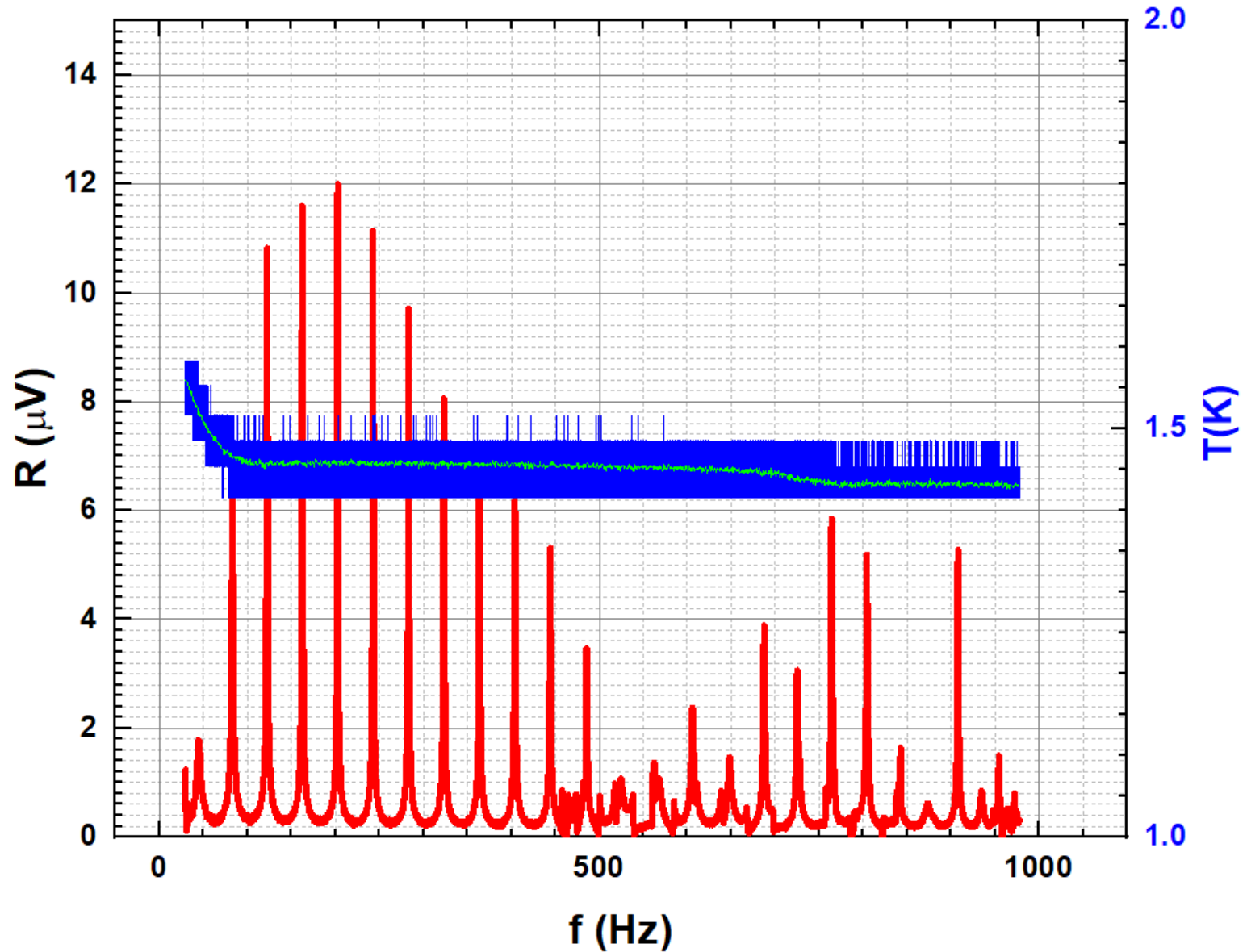

Graphical presentation of data: Extra Layer

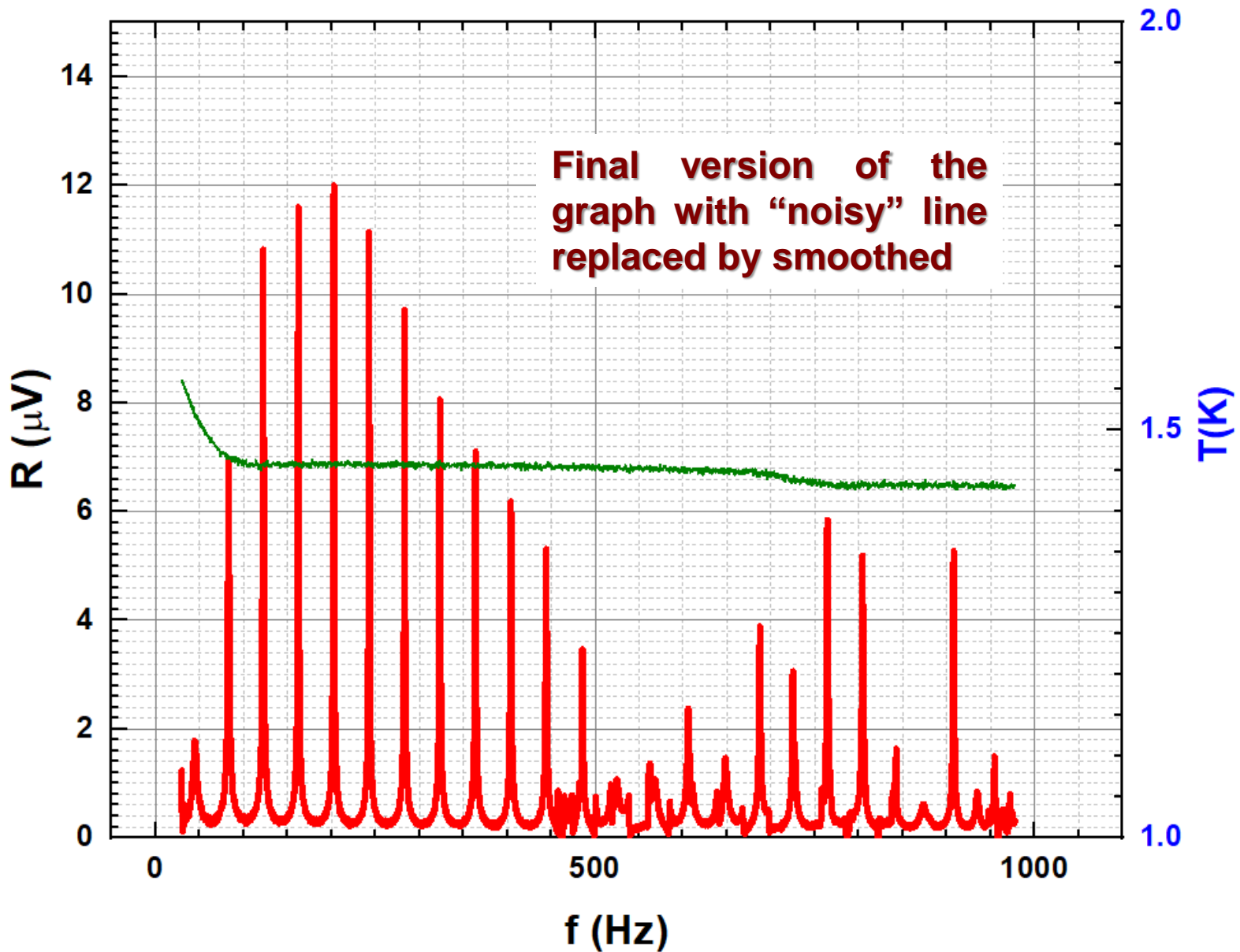

peaks

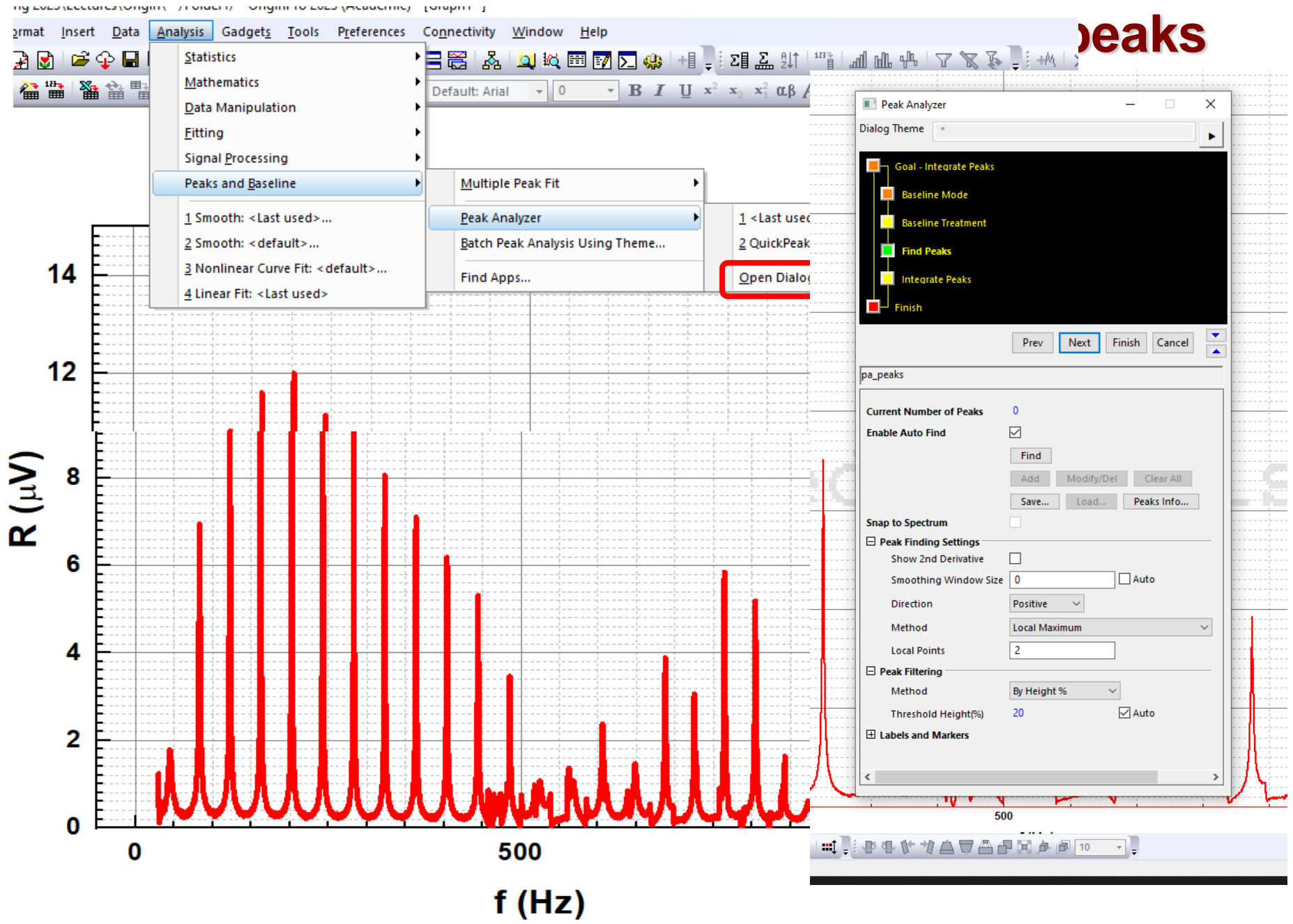

Graphical presentation of data: Finding peaks

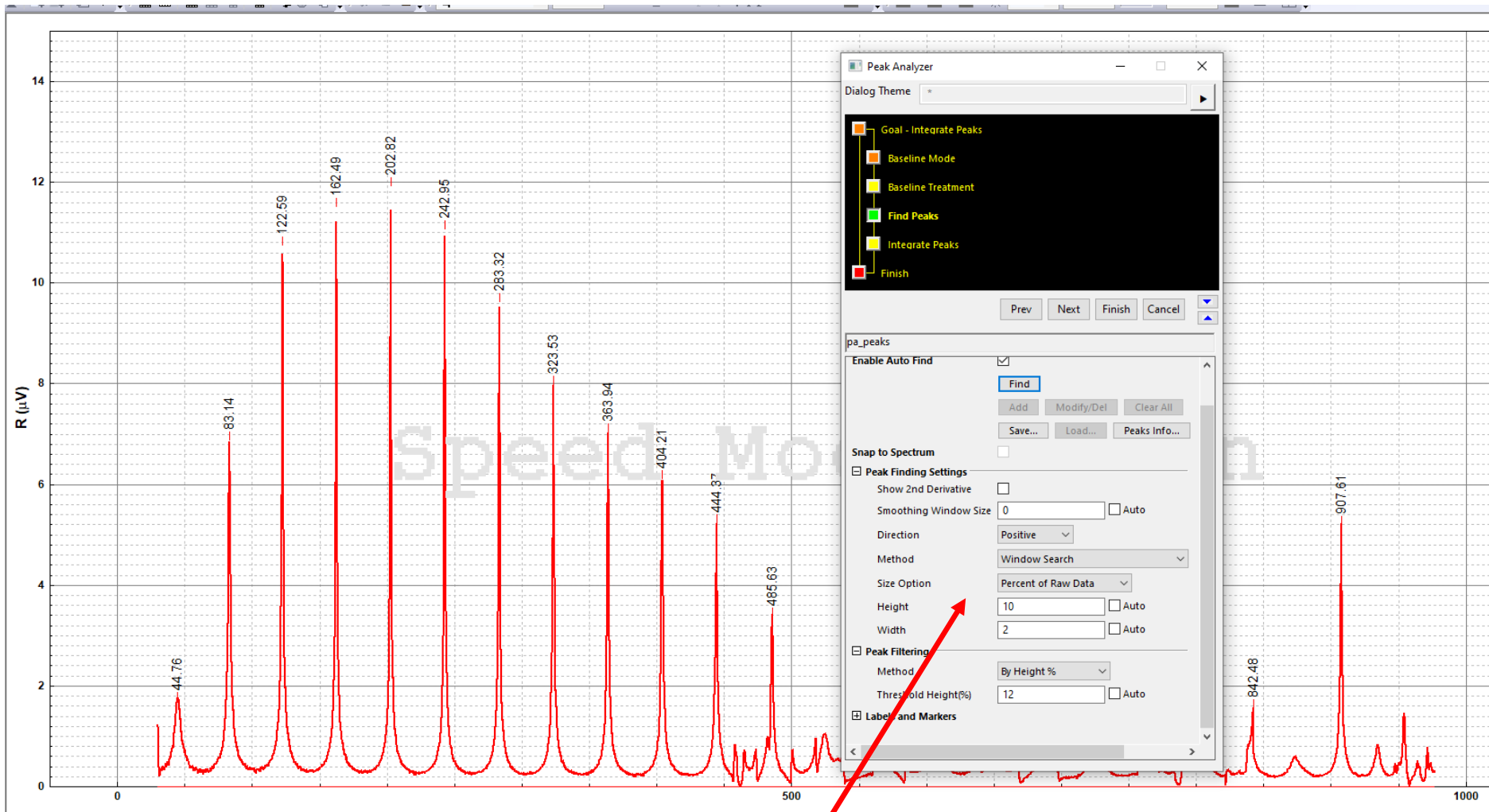

Choose the proper search parameters

Graphical presentation of data: Finding peaks

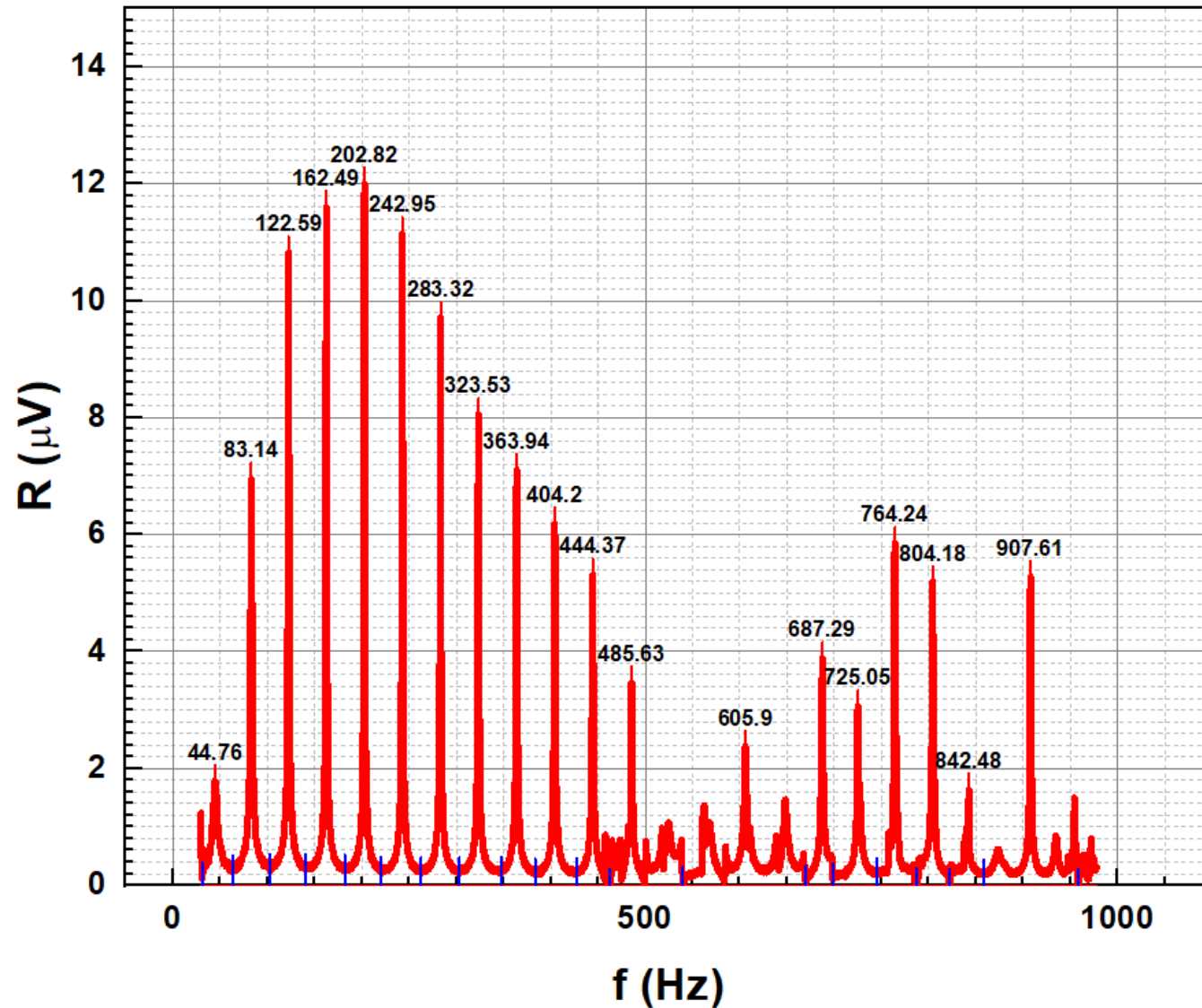

Graphical presentation of data: Multiple peak Fit

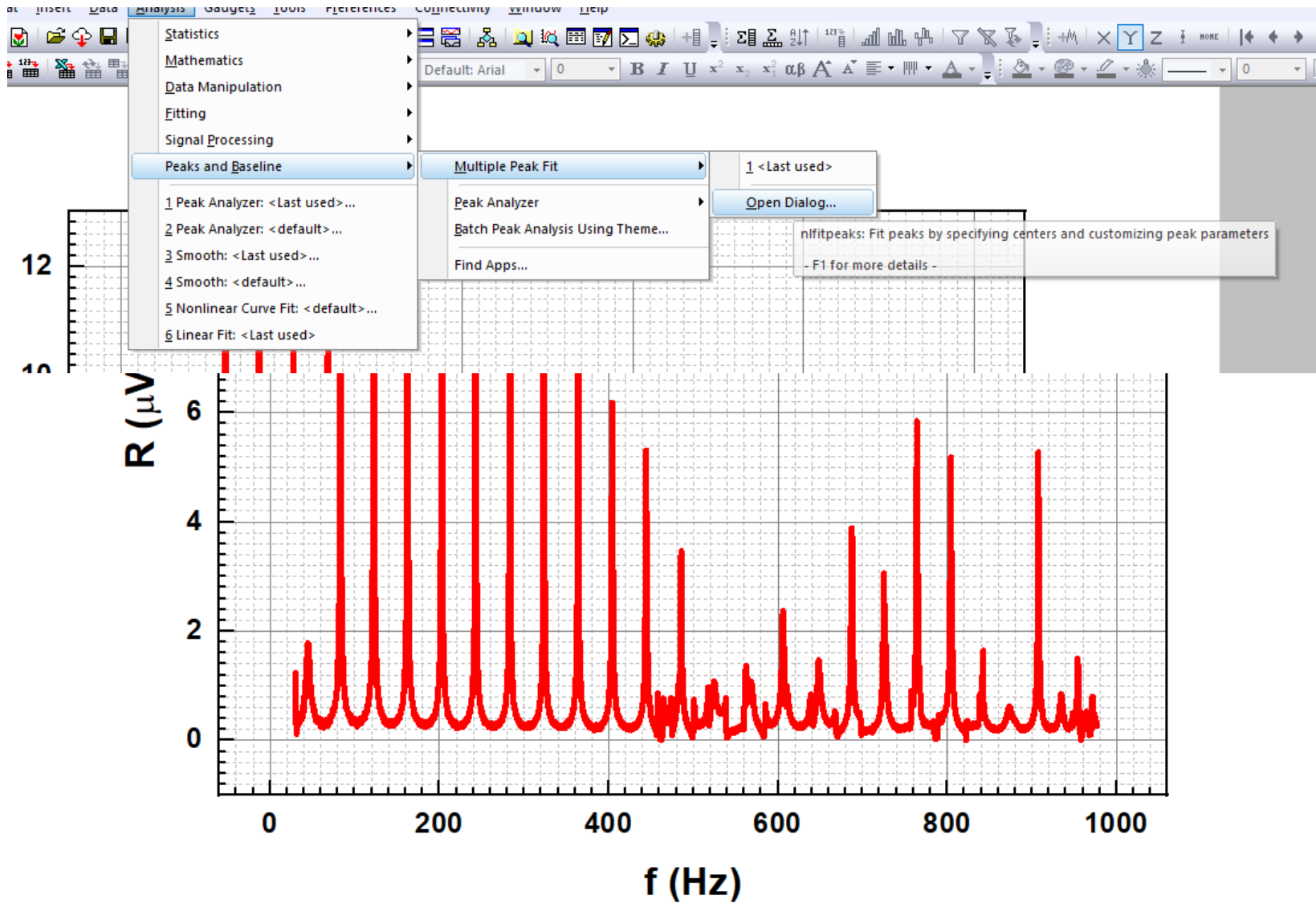

Graphical presentation of data: Multiple peak Fit

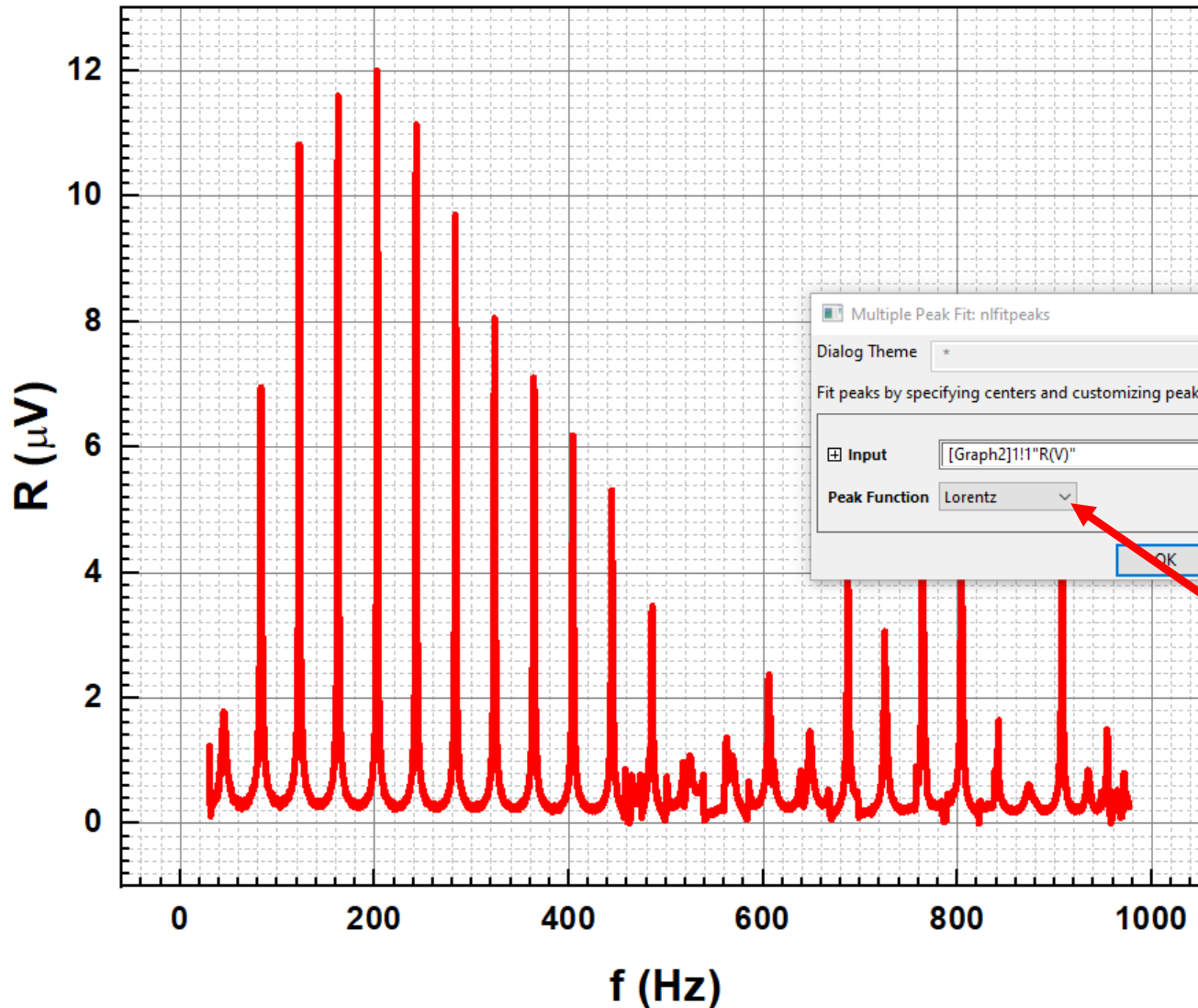

Choose the expected line shape

Graphical presentation of data: Multiple peak Fit

Manually mark the expected peak positions

Push
"Open Nlfit"

1

Get Points

Fit < You have picked 11 peaks.
X = 441.05263, Y = 6.20261E-6

Open NlFit

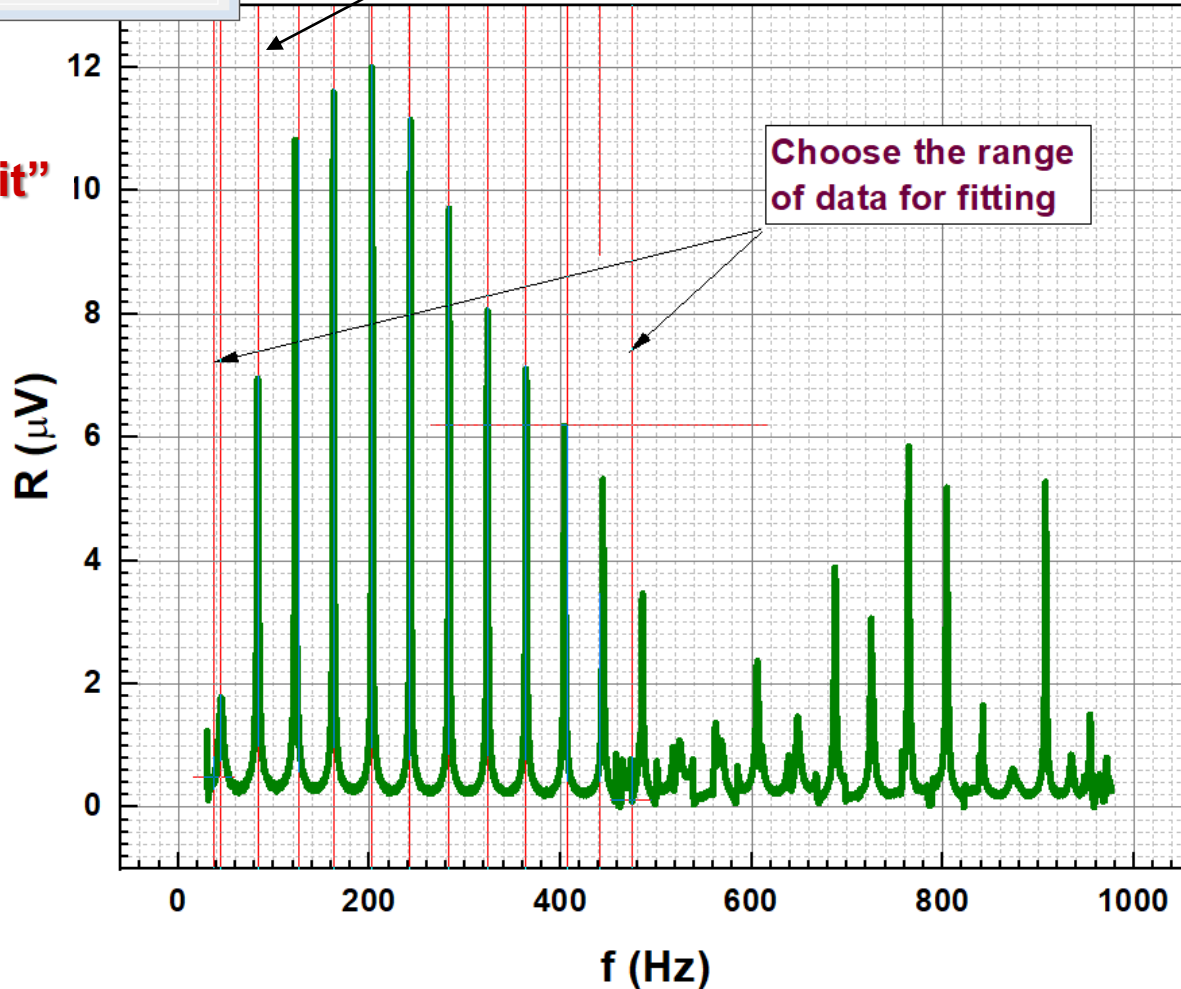

Graphical presentation of data: Multiple peak Fit

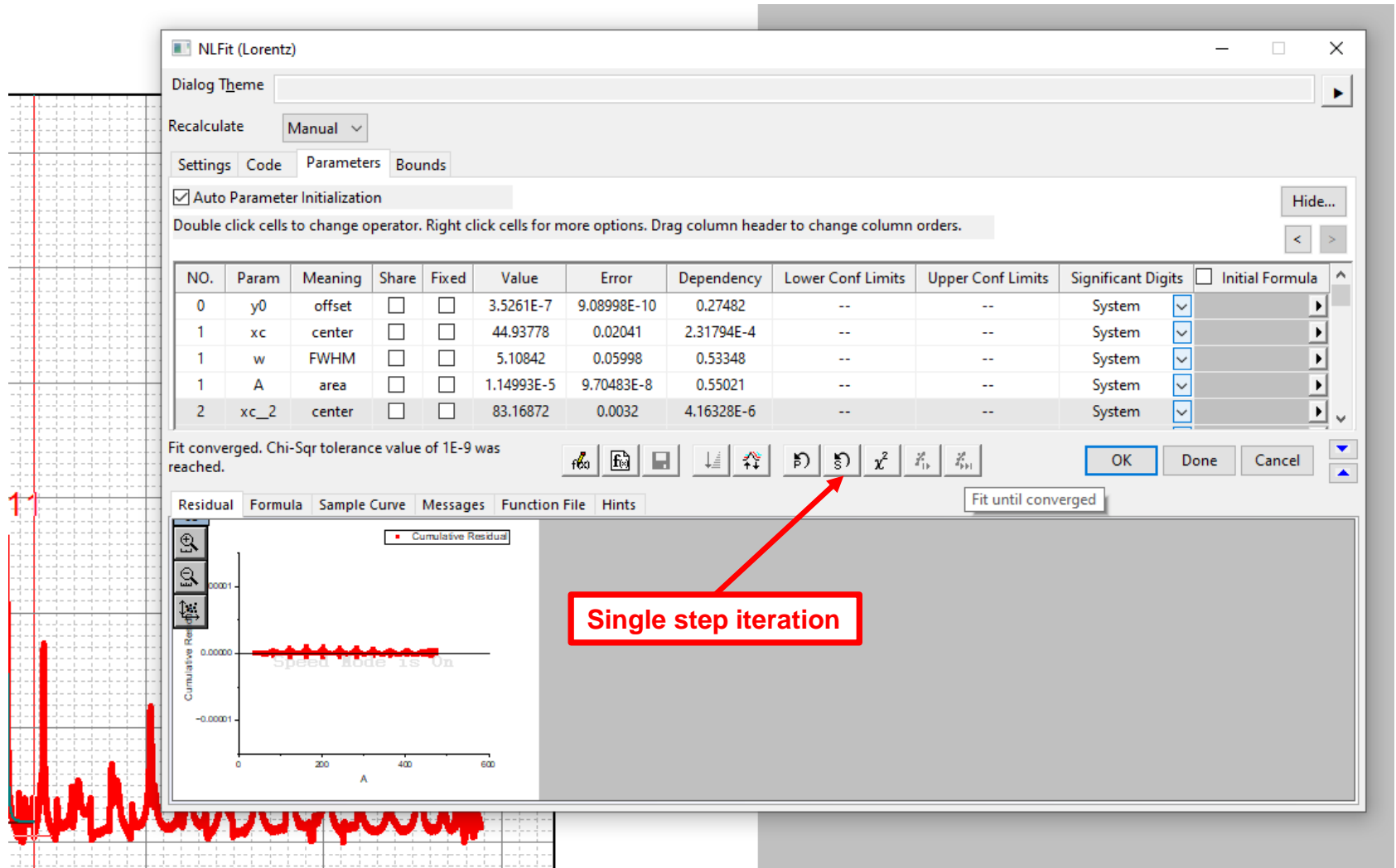

Recommendation: start first with "Single step iteration" and next if fitting goes in proper direction push "Fit until converged"

Graphical presentation of data: Multiple peak Fit

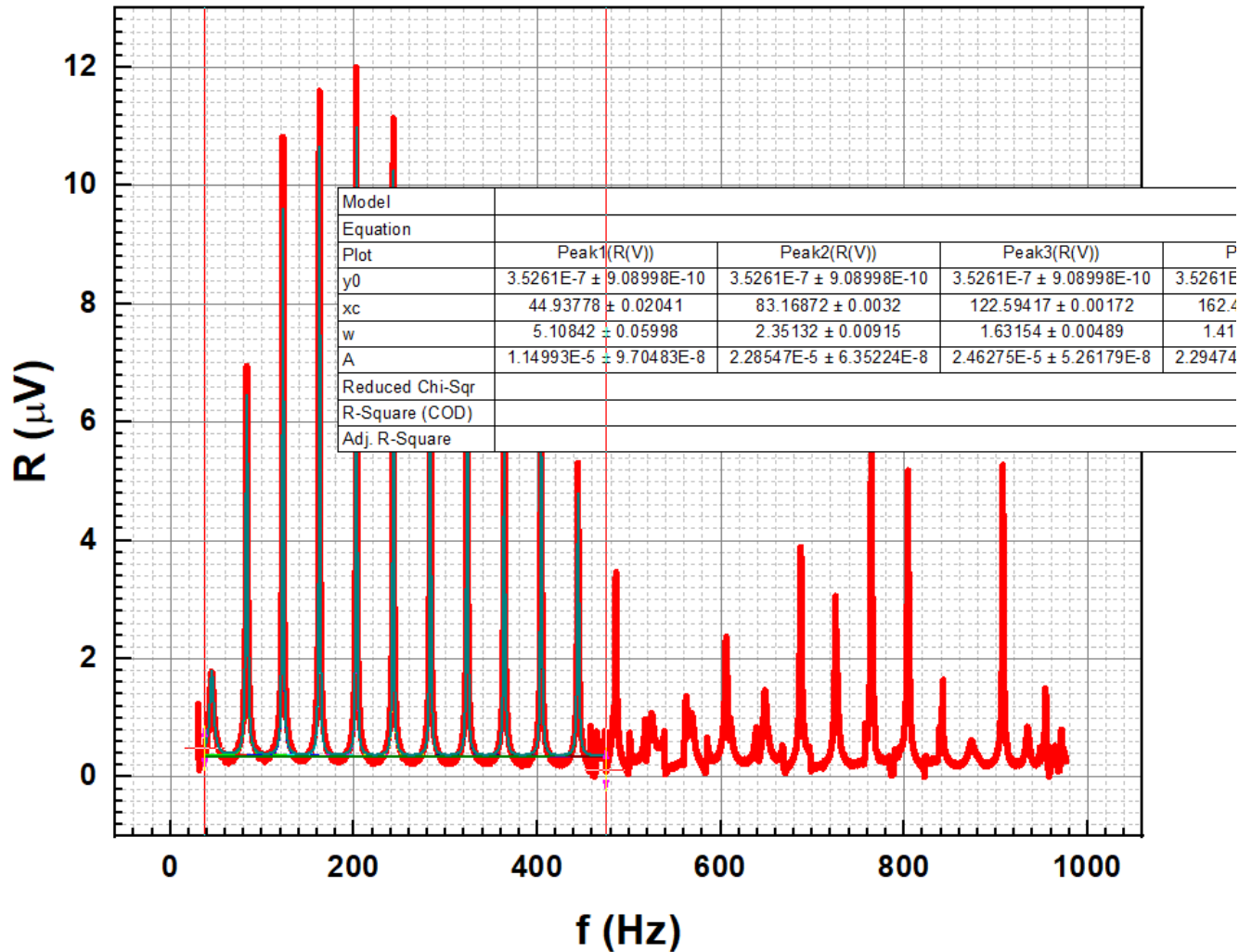

Finally, you will have the data plot with set of fitting lines plus the table with found parameters

Graphical presentation of data: Multiple peak Fit

All fitting results could be found in added layer to data worksheet

100 : Fit converged. Chi-Sqr tolerance value of 1E-9 was reached.

Summary

	y0		xc		w		A		H		Statistics	
	Value	Standard Error	Value	Standard Error	Value	Standard Error	Value	Standard Error	Value	Standard Error	Reduced Chi-Sqr	Adj. R-Square
Peak1(R(V))	3.5261E-7	9.08998E-10	44.93778	0.02041	5.10842	0.05998	1.14993E-5	9.70483E-8	1.43306E-6	1.15019E-8	2.62144E-14	0.98415
Peak2(R(V))	3.5261E-7	9.08998E-10	83.16872	0.0032	2.35132	0.00915	2.28547E-5	6.35224E-8	6.18792E-6	1.68499E-8		
Peak3(R(V))	3.5261E-7	9.08998E-10	122.59417	0.00172	1.63155	0.00489	2.46275E-5	5.2618E-8	9.60952E-6	2.02275E-8		
Peak4(R(V))	3.5261E-7	9.08998E-10	162.49202	0.0015	1.41975	0.00426	2.29474E-5	4.90025E-8	1.02897E-5	2.16838E-8		
Peak5(R(V))	3.5261E-7	9.08998E-10	202.81031	0.00139	1.30551	0.00395	2.17874E-5	4.69447E-8	1.06244E-5	2.26126E-8		
Peak6(R(V))	3.5261E-7	9.08998E-10	242.93645	0.0015	1.32379	0.00428	2.05619E-5	4.72812E-8	9.88834E-6	2.24559E-8		
Peak7(R(V))	3.5261E-7	9.08998E-10	283.3134	0.0018	1.42423	0.00513	1.91415E-5	4.90864E-8	8.55609E-6	2.16497E-8		
Peak8(R(V))	3.5261E-7	9.08998E-10	323.52904	0.00231	1.60858	0.00659	1.79125E-5	5.22522E-8	7.08916E-6	2.03714E-8		
Peak9(R(V))	3.5261E-7	9.08998E-10	363.9371	0.0027	1.70221	0.00769	1.67149E-5	5.37935E-8	6.25132E-6	1.98032E-8		
Peak10(R(V))	3.5261E-7	9.08998E-10	404.21923	0.0032	1.8129	0.00913	1.54766E-5	5.5566E-8	5.43479E-6	1.91892E-8		
Peak11(R(V))	3.5261E-7	9.08998E-10	444.35606	0.00381	1.89097	0.01086	1.38639E-5	5.67808E-8	4.66745E-6	1.8789E-8		

ANOVA

		DF	Sum of Squares	Mean Square	F Value	Prob>F
R(V)	Regression	33	7.12026E-8	2.15765E-9	82307.90245	<0.0001
	Residual	43715	1.14596E-9	2.62144E-14		
	Uncorrected Total	43749	1.01914E-7			
	Corrected Total	43748	7.23485E-8			

R(V): At the 0.05 level, the fitting function is significantly better than the function y=constant.

Fitted Curve

R(V)

Run1 1V_long | nlfiteaksCurve1 | nlfiteaks2 | nlfiteaksCurve2 | X = 277.281465, Y(/1e-06) = 13.5085131



This layer contains all fitting results

Graphical presentation of data: Multiple peak Fit

Comparing the results obtained by using
“Peak find” and “Multipeak fit” procedures

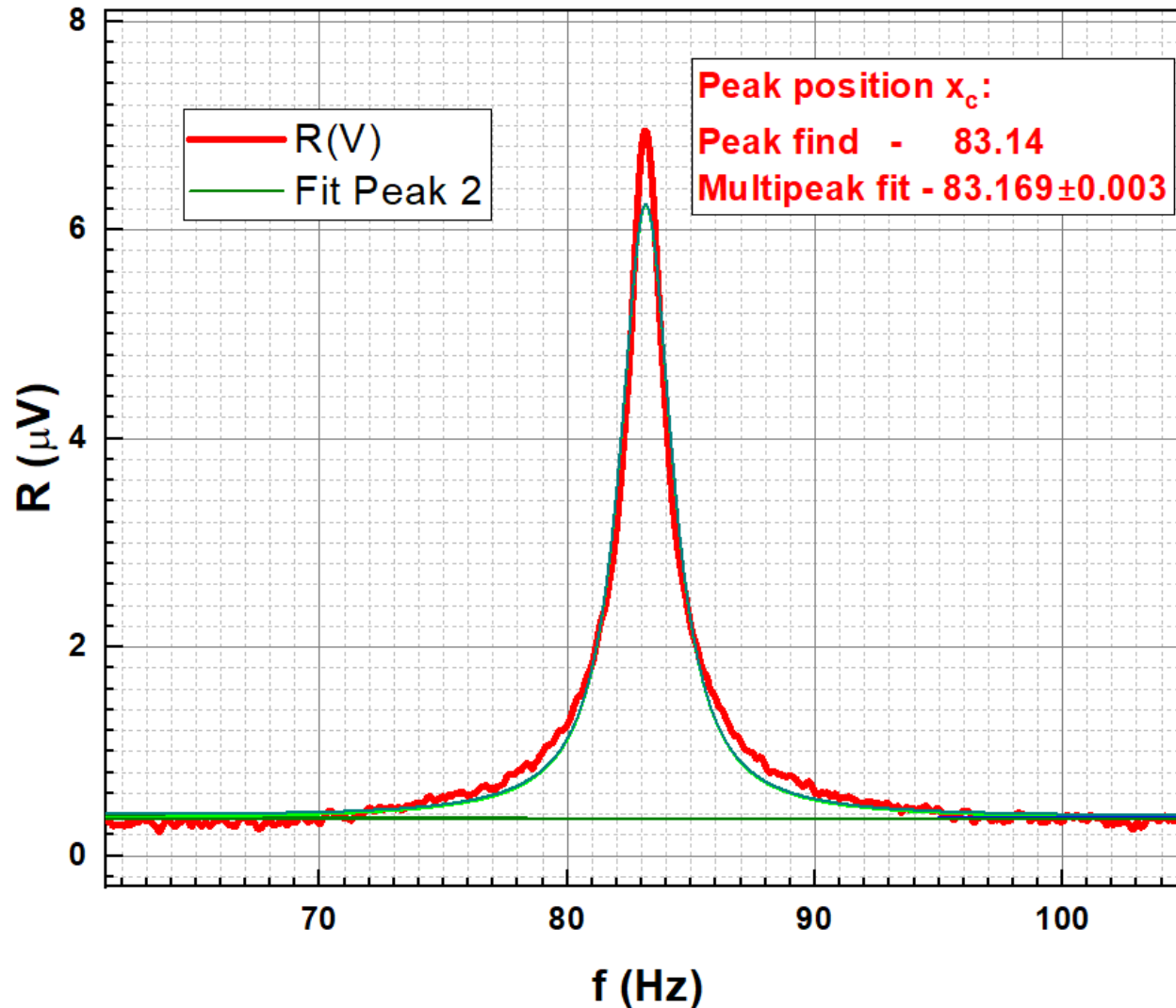

Graphical presentation of data: Fit Linear

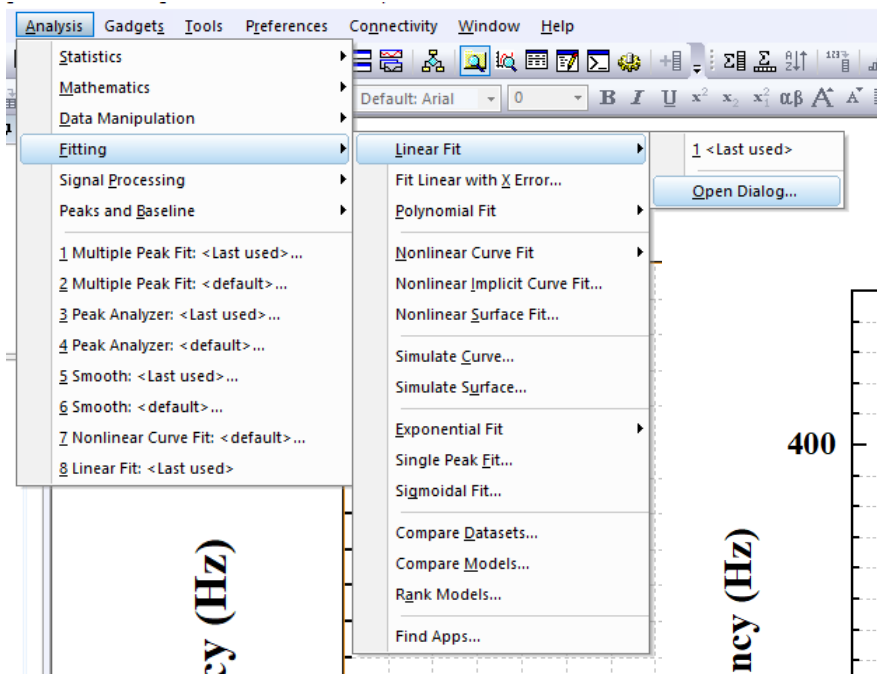

**Example of linear fitting.
Data from *Second sound*
experiment**

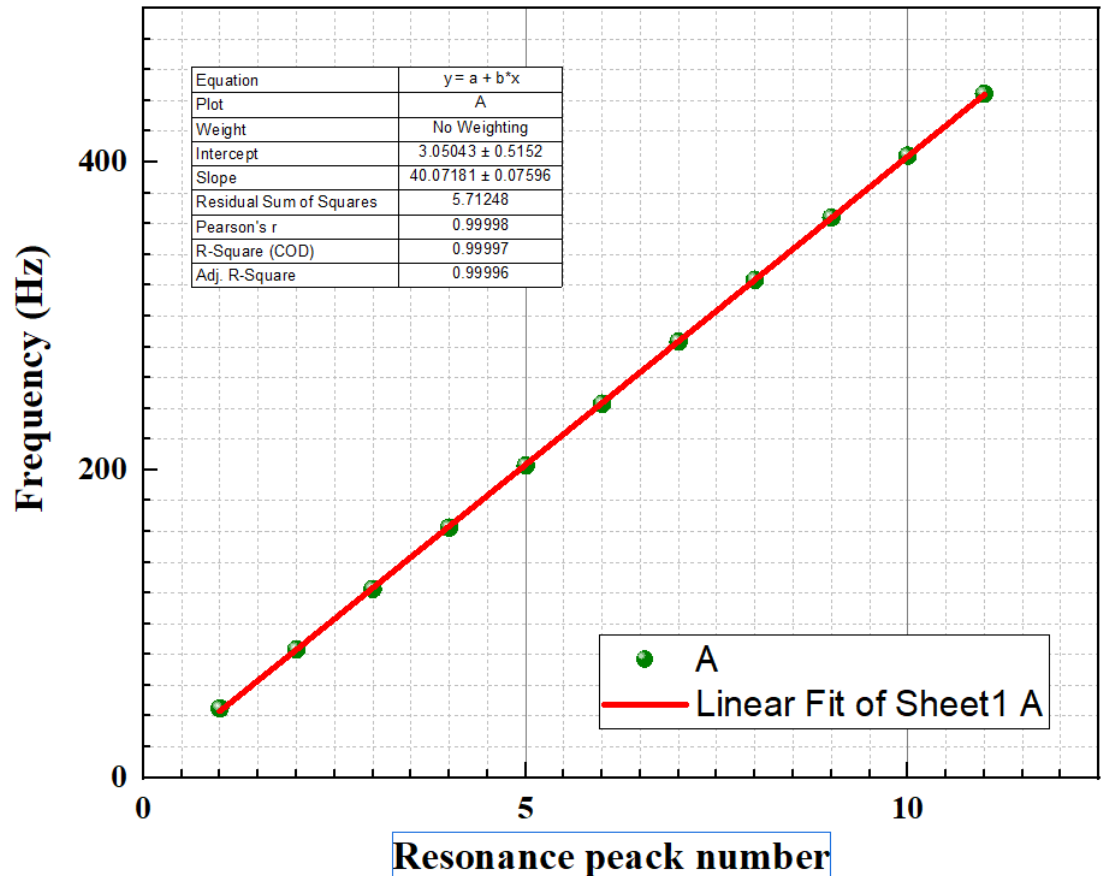

Graphical presentation of data: Fit Polynomial

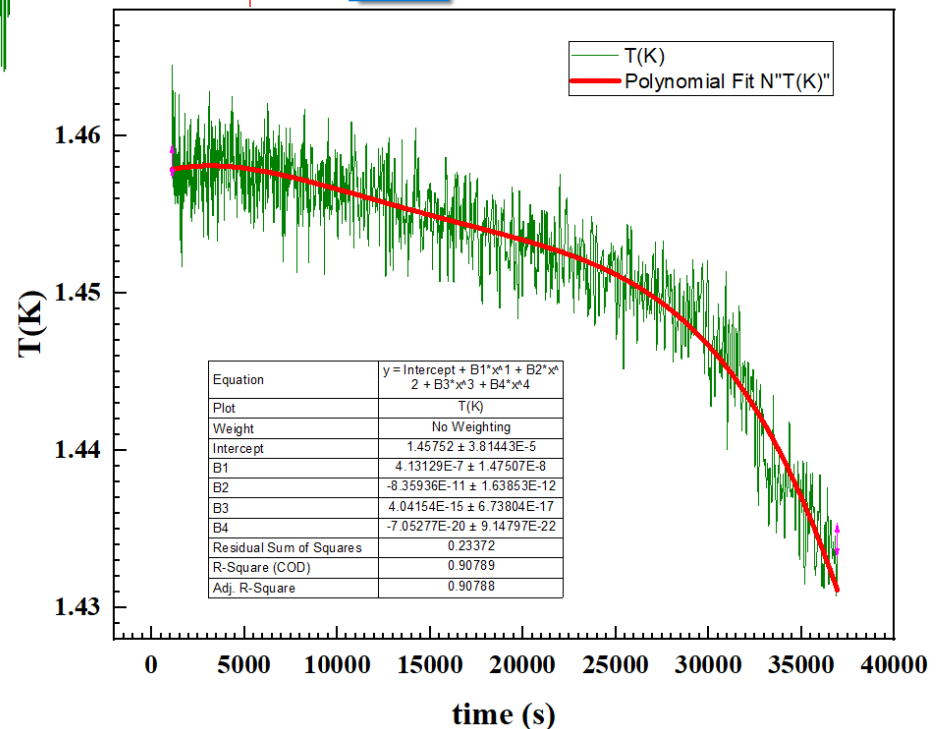
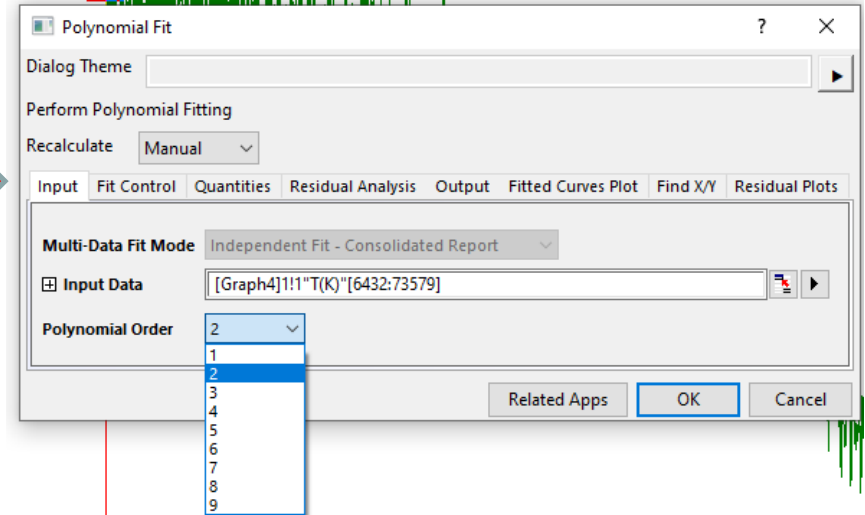
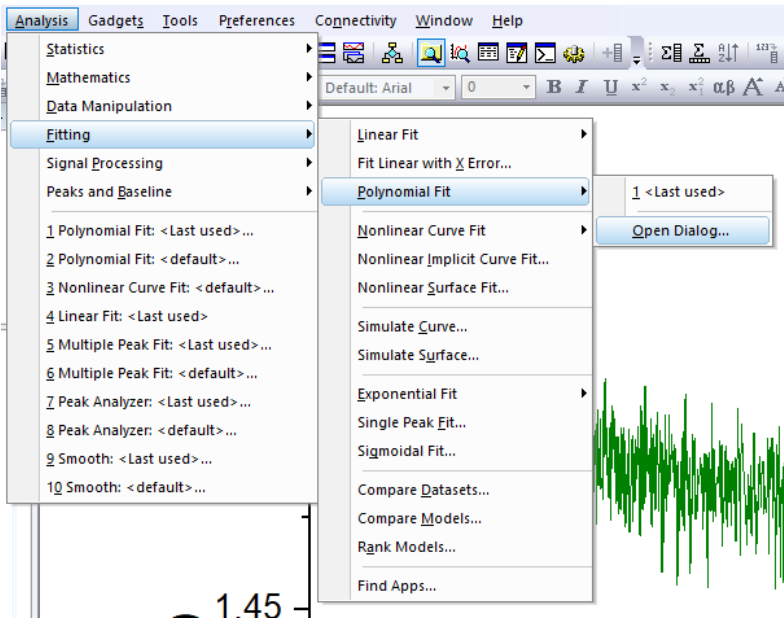

Graph showing the temperature variations during the taking data with results of polynomial fit

Working with data: Worksheets. Statistics on Column

The screenshot shows a spreadsheet with columns A(H) and rows 1-32. Column C(K) is selected, and a context menu is open. The 'Statistics on Column' option is highlighted. A dialog box titled 'Statistics on Columns (1/25/2023 14:52:11)' is displayed, showing a table of descriptive statistics for column C(K).

	N total	Mean	Standard Deviation	Sum	Minimum	Median	Maximum
T(K)	94340	1.45169	0.02566	136952.32874	1.41557	1.45404	1.58361

The results could find here

The screenshot shows a file explorer window with a folder named 'DescStatsOnCols1' selected. The address bar shows the path 'FitPolynomial3 \ DescStatsOnCols1 /' and the current view is set to '10'.

Working with data: Worksheets. "Set Column Values"

The image shows a screenshot of the LabTalk software interface. A context menu is open over column B, with the 'Set Column Values...' option selected. A dialog box titled 'Set Values - [SecondSound2]\'SecondSound_T2_16K VE...' is open, showing the formula `col(B) = col(B) - 273`. A data table is visible in the background, showing columns for time (s), temperature (T(K)), pressure (P (mm)), and other parameters. A large blue arrow points from the dialog box to the data table.

	A(X)	B(Y)	C(Y)	D(Y)	E(Y)	F(Y)	G(Y)	H(Y)	I(Y)
Long Name	time (s)	T(K)				f (Hz)	X (V)	Y(V)	R(V)
Units									
Comments									
F(x)=									
Sparklines									
1	5.35899	1.571							
2	5.84299	1.571							
3	6.281	1.571							
4	6.71799	1.571							
5	7.172	1.571							
6	7.60899	1.571							
7	8.437	1.571							
8	8.906	1.571							
9	9.39	1.571							
10	9.85899	1.571							
11	10.297	1.571							
12	10.71799	1.571							
13	11.156	1.571							
14	11.59299	1.571							
15	12.031	1.571							
16	12.46799	1.571							
17	12.89	1.571							
18	13.312	1.571							
19	13.73399	1.571							

Layouts

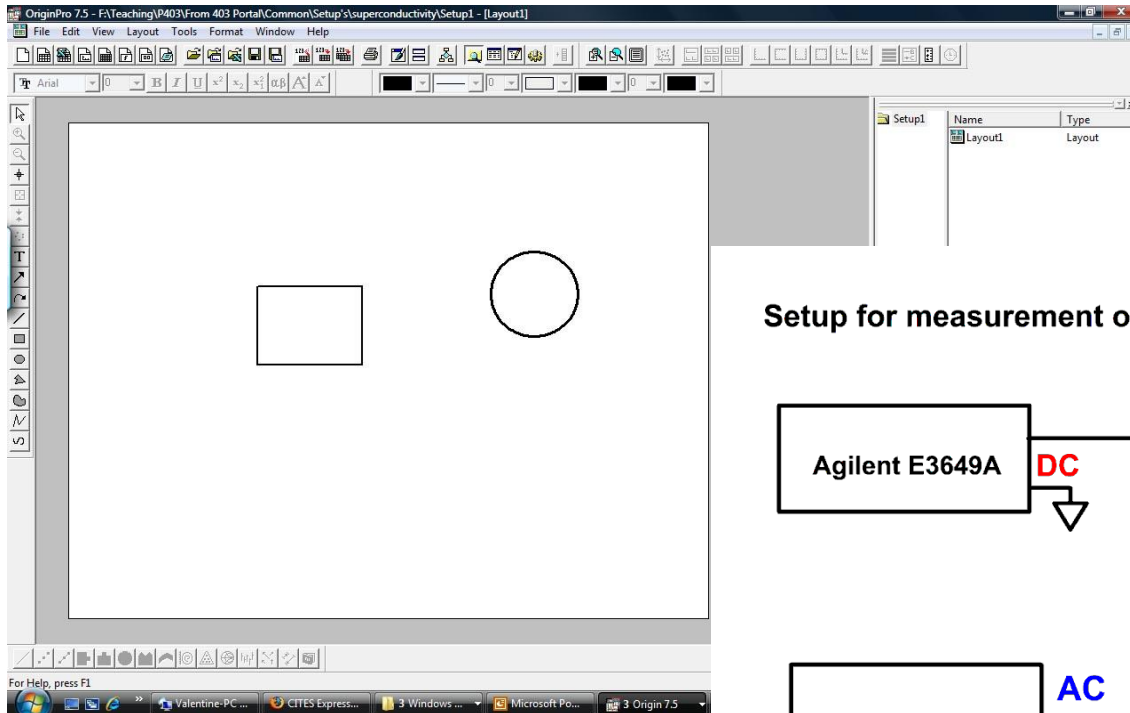

Setup for measurement of s/c properties

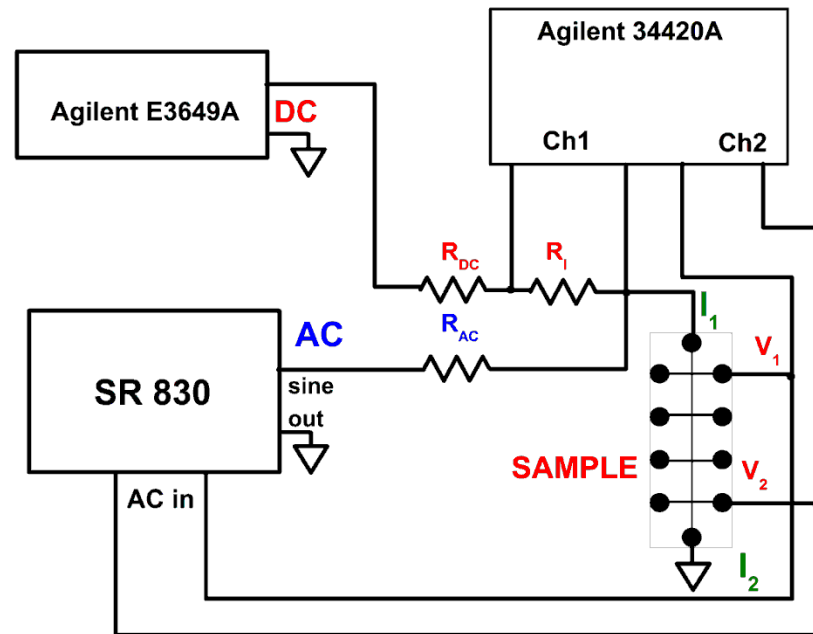

Custom tools

The screenshot displays the OriginPro 2015 (Academic) 64-bit interface. The main window shows a spreadsheet titled 'Book1' with columns 'A(X)' and 'B(Y)'. The spreadsheet contains the following data:

	A(X)	B(Y)
Long Name		
Units		
Comments		
F(x)=		
1		
2		
3		
4		
5		
6		
7		
8		
9		
10		
11		

The 'Tools' menu is open, showing the following options:

- Options... (Ctrl+U)
- Fitting Function Builder... (F8)
- Virtual Matrix Manager...
- Transfer User Files...
- Digitizer...** (highlighted)
- Video Builder...

The interface also includes a Project Explorer (1) on the left, a Quick Help pane, a Messages Log, and a Smart Hint Log. The status bar at the bottom indicates 'Sheet1'.

Using digitizer script

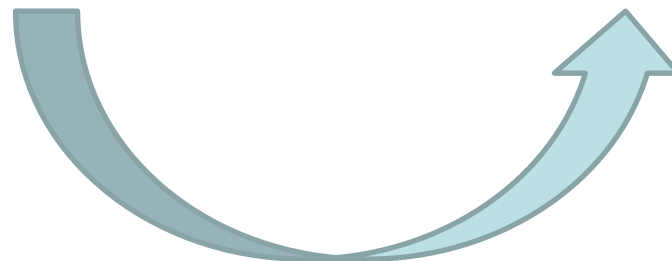
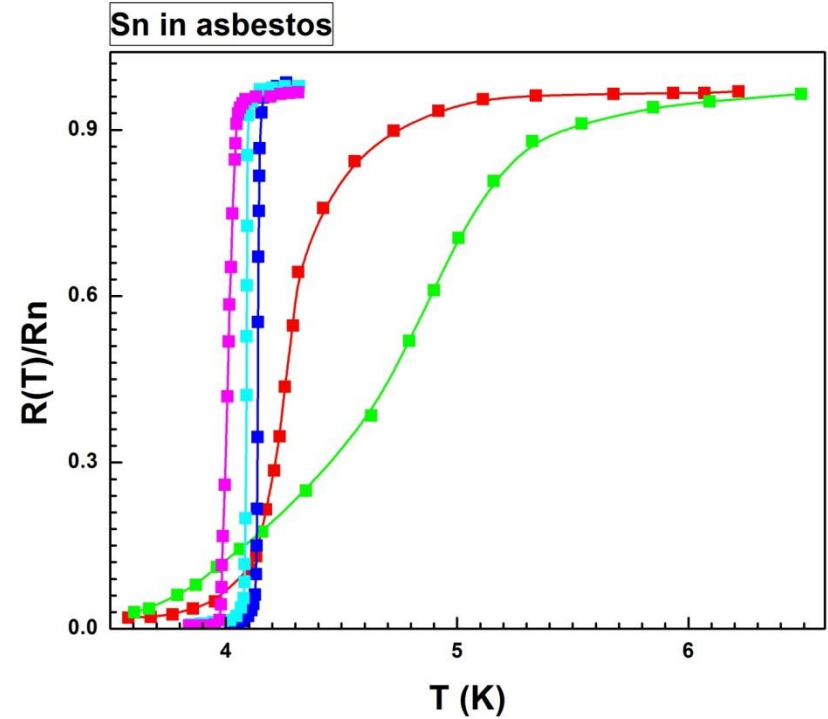
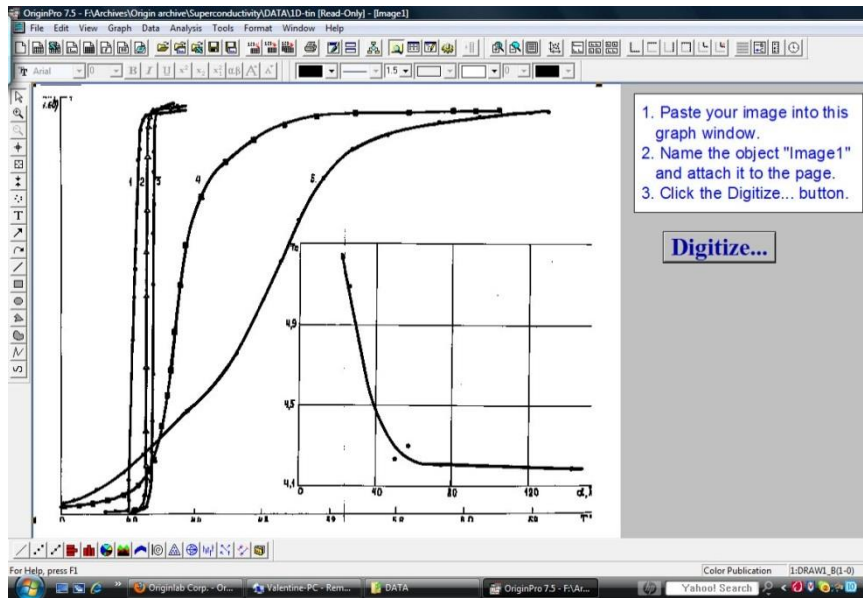

Example Origin graphs

$(\text{PMN})_{0.87}(\text{PT})_{0.13}$, single crystal

Ferroelectric
Experiment

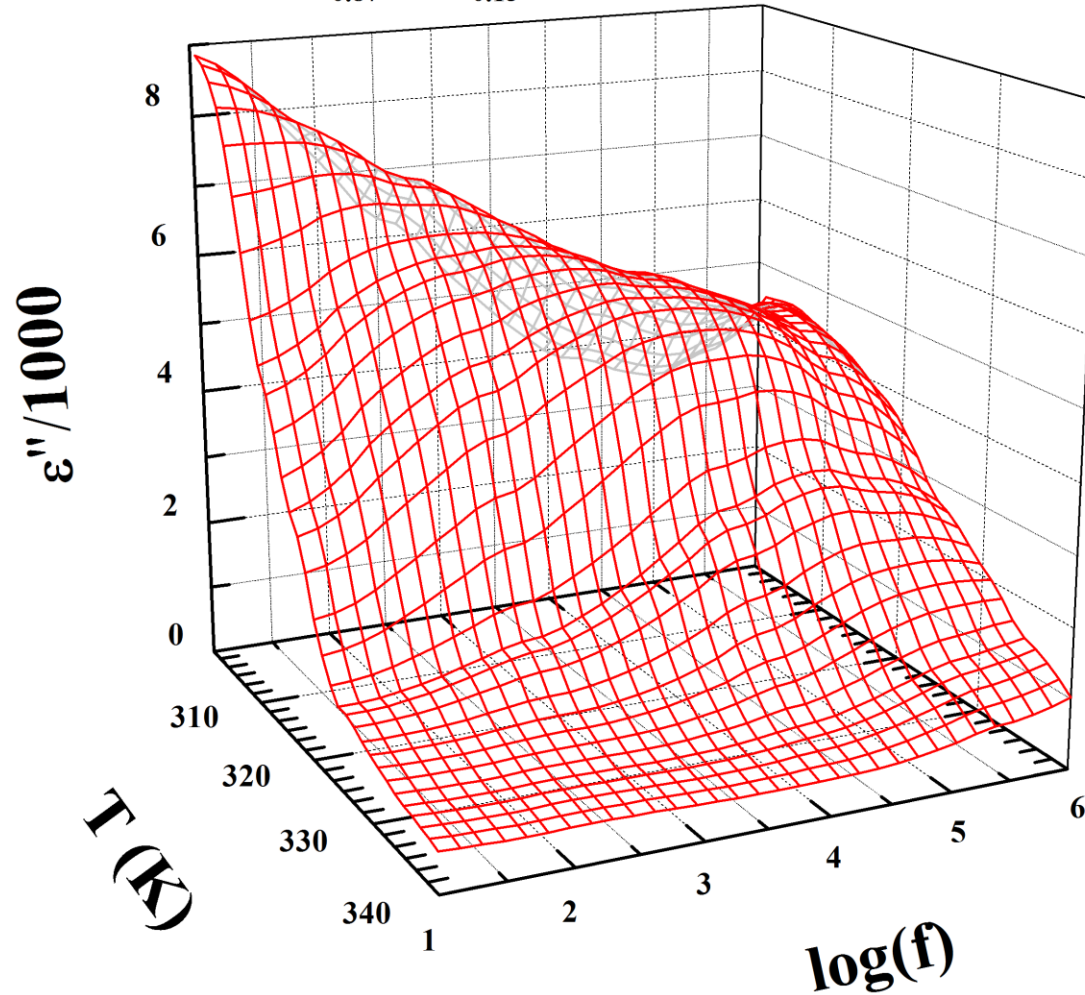

Example Origin graphs

Ferroelectric
Experiment

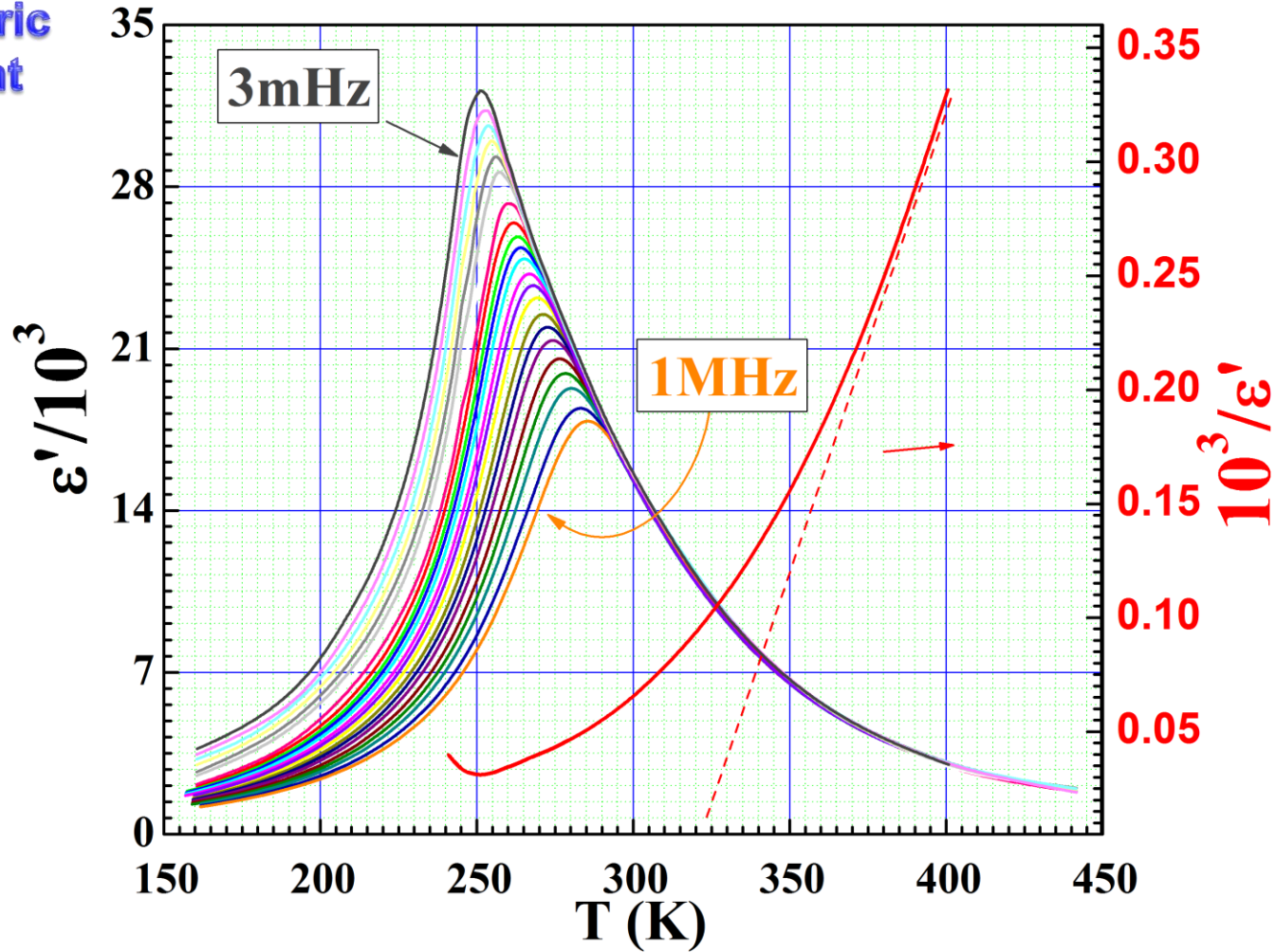

Example Origin graphs

Optical
pumping

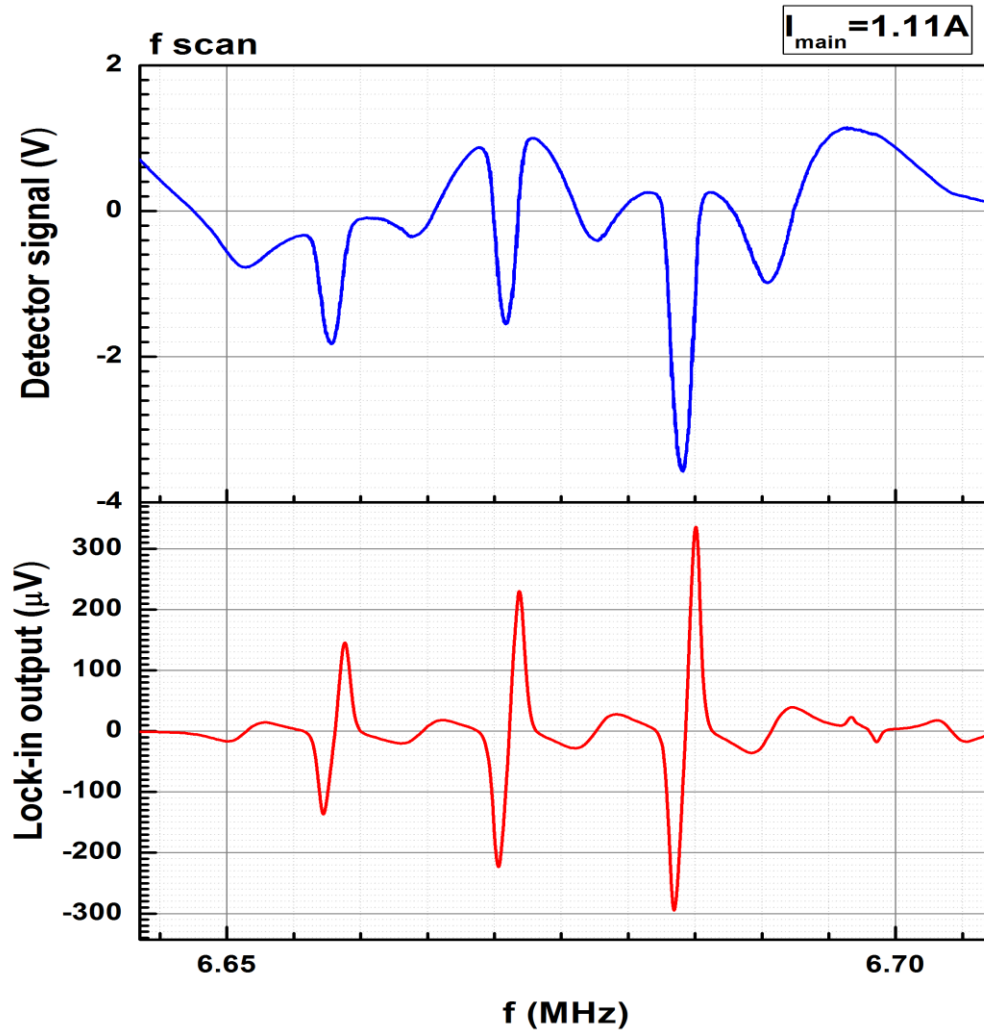

Mapping 0.5-2.5A from March 1st 2012: Graph7



Example Origin graphs

Tunneling
Experiment

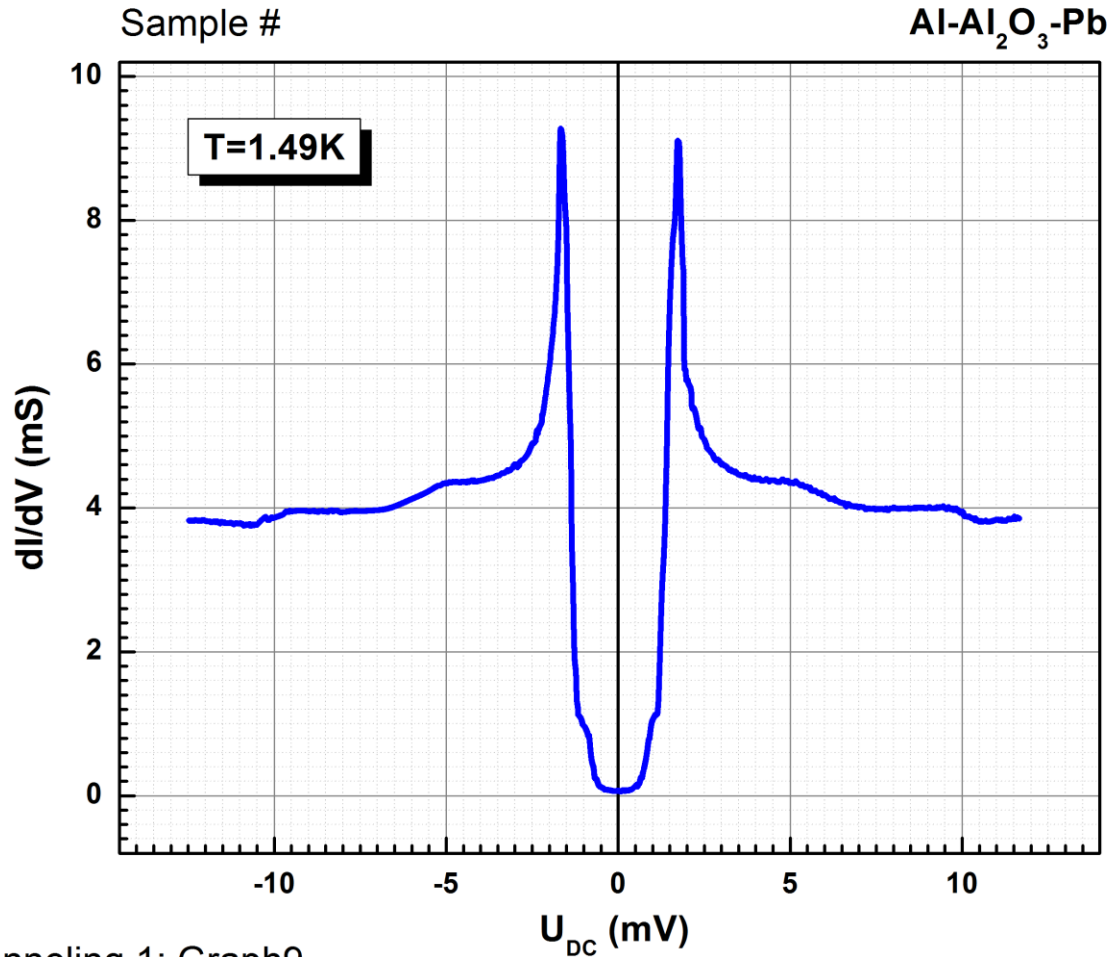

Tunneling 1: Graph9

Sample n2 run8 zoom temp 1.55K



Example Origin graphs

Second
sound

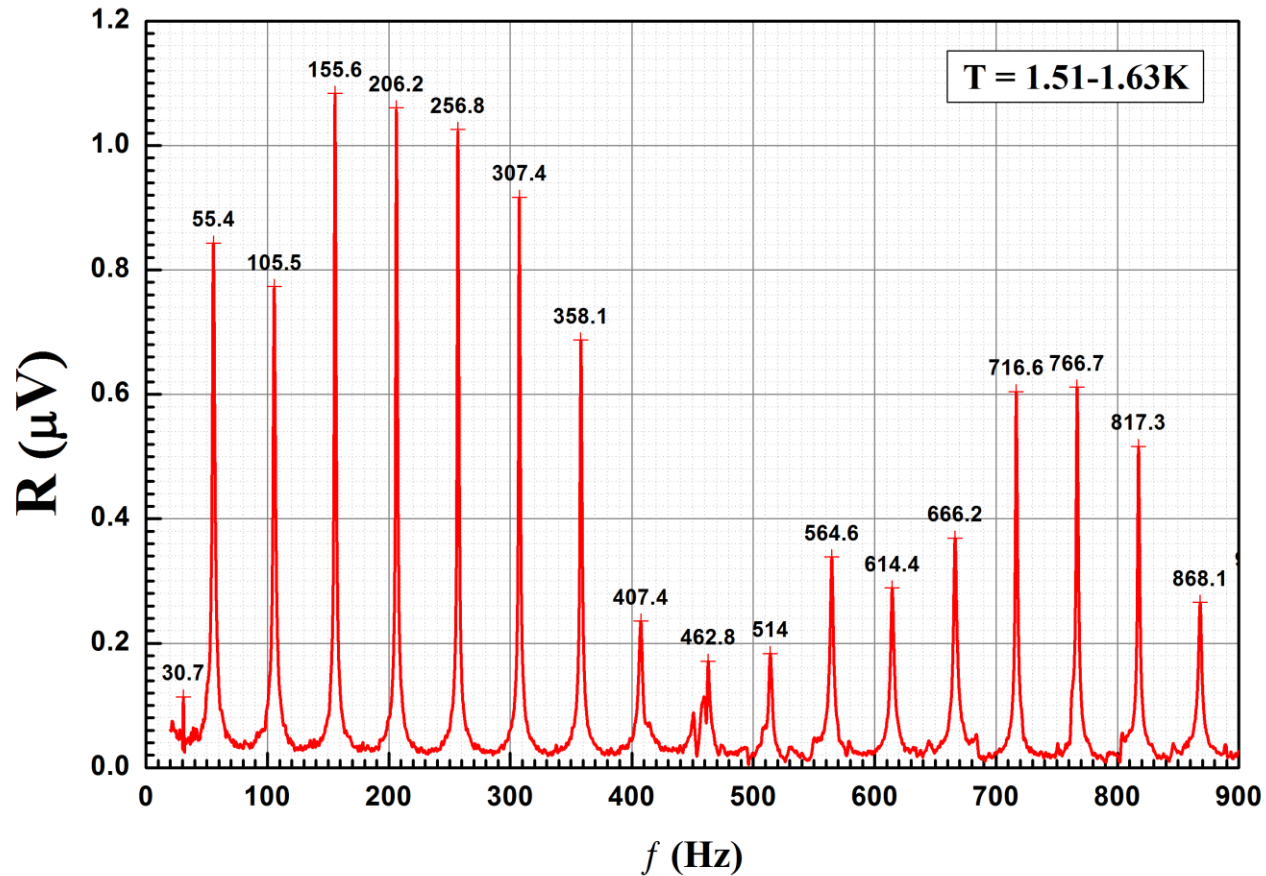

Example Origin graphs

Magnet mapping

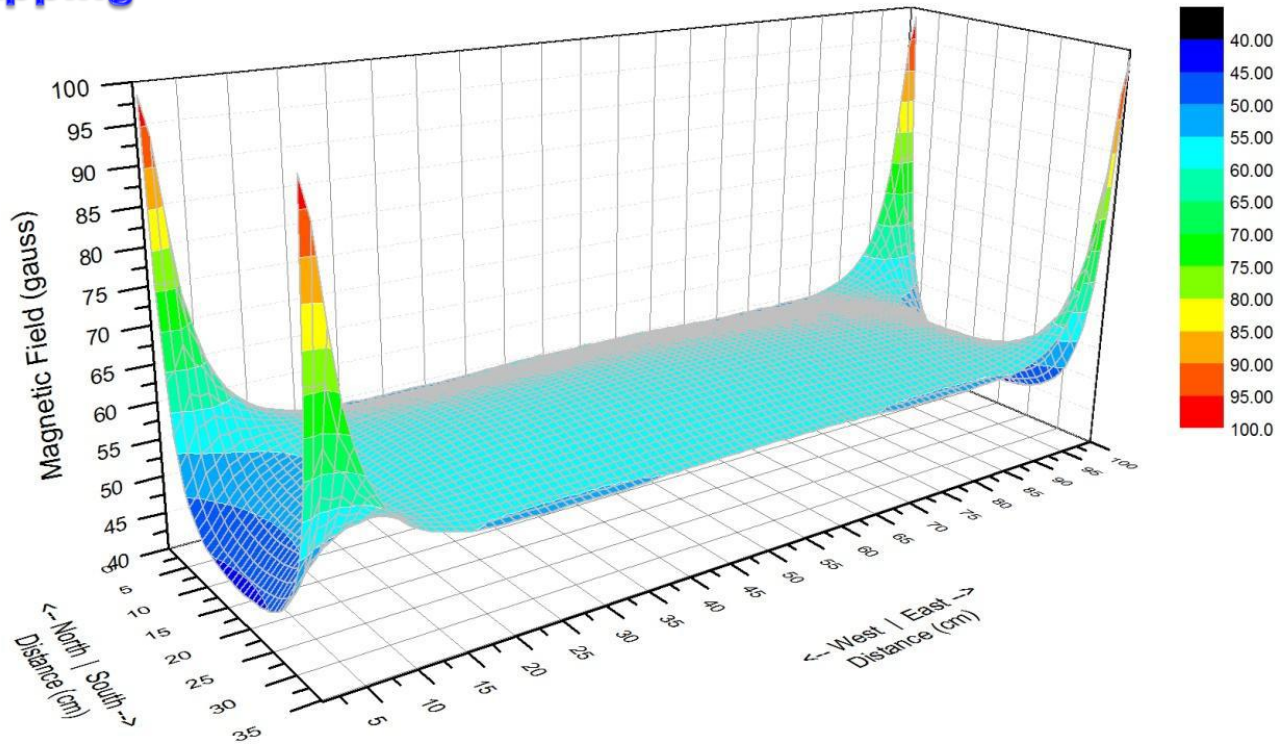

Origin at UIUC Webstore and OriginLab site.

WEBSTORE

URBANA-CHAMPAIGN
CHICAGO • SPRINGFIELD

SHOP PERSONAL PURCHASES

SHOP UNIT PURCHASES



| HOME | ABOUT US | EVENTS | NEWS | FAQ | SUPPORT

PRODUCT SEARCH: GO BROWSE ALL

[Home](#) > [Personal Purchase](#) > [Software](#) > [Free Software](#)

My Account

Login: You are a Guest

[My Profile](#)

[Order History](#)

[View Cart \(0 items\)](#)

OriginPro License ESD (Expires 6/30/2023)

Free



OriginLab, Inc.

Eligibility: UIC Faculty, UIC Staff, UIC
Employee type - G, UIU Faculty and



30+ years serving the scientific and engineering community

Buy Now Try Origin for Free Watch Videos English Log In

Products ▾ Apps ▾ Purchase ▾ Support ▾ Communities ▾ About Us ▾ Contact Us

- ✓ 3D Surface
- ✓ 3D Scatter, Vector
- ✓ 3D Bars, Ribbons, Walls
- ✓ 3D Waterfall
- ✓ 3D Parametric Function Plot
- ✓ 3D Ternary
- ✓ Plot from XYZ, Matrix or Worksheet

Up-Coming Webinars
View Schedule

>> Free Origin Viewer 9.9.5
>> New Apps: Pulse Fit, Propagation of Error, Bootstrap Sampling, Effect Size for ANOVA, Steel-Dwass Test ...

<https://webstore.illinois.edu>

www.originlab.com

ORIGINPRO® 2023
The Ultimate Software for Graphing & Analysis

Get Started for Free

Upgrade to Origin 2023

See what people are saying about
Origin

Over 500,000 registered users across corporations, universities and government research labs worldwide, rely on Origin to import, graph, explore, analyze and interpret their data. With a point-and-click interface and tools for batch operations, Origin helps them optimize their daily workflow. Browse the sections below to learn more.

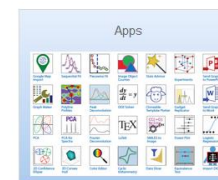
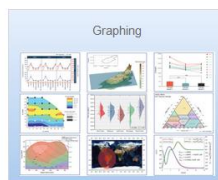

illinois.edu

Running Origin remotely

Here is another way to run Origin without needing to install it on your own computer (e.g. if you have a Mac, which is not supported by Origin):

1. Connect to VPN
2. Install and run Citrix:
<http://it.engineering.illinois.edu/ews/lab-information/remote-connections/connecting-citrix>
3. Click on "Apps" and then "Origin"
4. To open and save files, use your EWS folder at this address: "smb://ad.uillinois.edu/engr-ews/[Your netID]"



Origin manuals



30+ years serving the scientific and engineering community

Log In

Buy Now

Try Origin for Free

Watch Videos

English

Products

Apps

Purchase

Support

Communities

About Us

Contact Us

Search



All Books > Tutorials >

Tutorials

- Getting Started
- User Interface
- Data Analysis
- Statistics
- Graphing
- Data Management
- Data Exploration
- Importing Data
- Exporting and Presentation
- Collaboration and Connectivity
- Programming

English | Deutsch | 日本語

© OriginLab Corporation. All rights reserved.
Site Map | Privacy Policy | Terms of Use

Video Tutorials on the company website

<http://www.originlab.com/index.aspx?go=Get+Origin+Video+Tutorials>



VIDEOS

Installation and Licensing

Introduction to Origin

All video tutorials

DOCUMENTATION

User Guide

Tutorials

Python Programming









OriginC Programming

LabTalk Programming

All documentation

Origin manuals

Video Tutorials on the company website

Title	Category	Length	PlayNow	LastUpdated	Version	Audio	Youtube
Origin 2023 Highlights	General - Overviews	00:05:26		11/1/2022	10.0	Y	YouTube
Introduction to Origin/OriginPro	General - Overviews	00:02:30		6/9/2021	9.85	Y	YouTube
Getting Starting with Graphing	General - Overviews	00:04:14		10/18/2019	9.7	Y	YouTube
Bringing Data into Origin	General - Overviews	00:03:07		10/18/2019	9.7	Y	YouTube
Analysis with Auto Recalculations	General - Overviews	00:02:28		10/18/2019	9.7	Y	YouTube
Build Your Presentation in 60 Seconds	General - Overviews	00:01:22		1/5/2018	9.5	Y	YouTube
Origin Learning Center	General - Overviews	00:02:26		12/25/2017	9.5	Y	YouTube
Apps for Origin	General - Overviews	00:01:54		12/14/2017	9.5	Y	YouTube
Origin vs OriginPro	General - Overviews	00:06:56		6/14/2016	9.3	Y	YouTube

<http://www.originlab.com/index.aspx?go=SUPPORT/VideoTutorials>

